



CR Ferramentas Especiais



2019





CR Ferramentas Especiais



Forjados Especiais

LINHA UNIVERSAL- USO GERAL	1	Pág.
LINHA UNIVERSAL GUERRA 100 - SEXTAVADO	1.1	4
CABOS E EXTENSÕES	1.2	5
SOQUETES ESPECIAIS	1.3	6
CABOS E EXTENSÕES	1.4	6
- - LINHA BORRACHARIA - -		
CHAVES DE RODA	1.5	6
MANÍPULO E CABOS DE FORÇA	1.6	7
CHAVE DE RODA CRUZ	1.7	7
CHAVE DE RODA L	1.8	8
ESPÁTULAS	1.9	8
TRUCKS	1.10	9
RODAS E CAVALETES	1.11	10
SACA POLIAS - MINI EXTRATORES	1.12	11
TORX	1.13	11
CHAVE MULTIDENTADA	1.14	12
CHAVE SOQUETE HEXAGONAL	1.15	13
TROCA DE ÓLEO	1.16	13
SACA FILTROS - ÓLEO E COMUSTÍVEL	1.17	14
ALICATES ESPECIAIS	1.18	15
CHAVES PARA VELA	1.19	15
ENCOLHEDORES DE MOLA	1.20	16
EXTRATORES DIVERSOS	1.21	17
ELÉTRICA	1.22	18
FUNILEIRO / TAPECEIRO	1.23	19
FREIO	1.24	19
ESCAPAMENTOS	1.25	20
EQUIPAMENTOS / MEDIÇÃO	1.26	20
SUSPENSÃO	1.27	21
VÁLVULAS / MOTOR	1.28	21
ACESSÓRIOS	2	22
SUPORTES PARA CÂMBIOS / MOTORES , CAVALETES E OUTROS		
FIAT	3	23
VOLKSWAGEN	4	26
FORD	5	29
GENERAL MOTORS	6	31
MULTIMARCAS	7	33
		
DIESEL	8	
UNIVERSAL / DIESEL	8.1	35
MERCEDES BENZ / SCANIA	8.2	35
MAXION	8.3	36
MWM	8.4	36
VANS / PICK-UPS	8.5	36
BICOS INJETORES	8.6	38
KITS DE FERRAMENTAS P/ SINCRONISMO DE MOTORES	9	39
Automáticos	10	47
BANCADA DE SERVIÇO - SUPORTES E PAINÉIS	11	49

CHAVE L TIPO BIELA

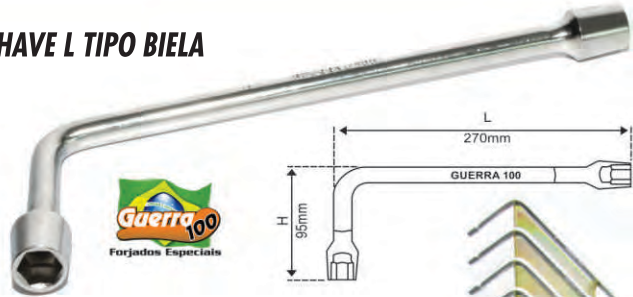

Material: Aço Especial - Temperado e Revenido
 Características: Forjada com 2 bocas usinadas, parede fina de alta resistência, cabeça cônica (externa)

CÓD.	MED. (mm)	CÓD.	MED. (mm)
G8	8	G14	14
G9	9	G15	15
G10	10	G16	16
G11	11	G17	17
G12	12	G18	18
G13	13	G19	19

Kg 5.15



CHAVE L TIPO BIELA BABY



Material: Aço Especial - Temperado e Revenido
 Características: Forjada com 2 bocas usinadas, parede fina de alta resistência, cabeça cônica (externa)
 Aplicação: A linha Guerra Baby por ter suas dimensões menores, permite o uso em locais de difícil acesso, principalmente na manutenção automotiva.

CÓD.	MED. (mm)	CÓD.	MED. (mm)
G-BY 6	6	G-BY 11	11
G-BY 7	7	G-BY 12	12
G-BY 8	8	G-BY 13	13
G-BY 9	9	G-BY 14	14
G-BY 10	10	G-BY 15	15



Kg 2.30

CHAVE L TIPO BIELA CANHÃO VAZADA



CÓD.	MED. (mm)	CÓD.	MED. (mm)
G-VZ	10	G-VZ	13
G-VZ	11	G-VZ	14
G-VZ	12		

cód.: Suporte 27004

CHAVE T COM CABO DESLIZANTE



CÓD.	MED.	∅	CÓD.	MED.	∅
G/T	6		G/T	13	1/2"
G/T	8		G/T	14	1/2"
G/T	10	1/2"	G/T	17	1/2"
G/T	12	1/2"	G/T	19	1/2"

cód.: Suporte 27003

CHAVE FIXA INTERCAMBIÁVEL ∅ 1/2"

CR 201 - c/ suporte



cód.: Suporte 27011

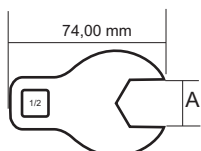

medidas (A)
 13, 14, 15, 16, 17, 18, 19, 21, 24 mm

Kg 1.10



SOQUETE SEXTAVADO LONGO ∅ 1/2"

Soquete sextavado longo (80mm) com meds: 6, 8, 10, 12, 13, 14, 17, 19 mm

(Jogo c/ 8 peças ou unitário)
 (Avulsos ou jogos c/ suporte)

(Ferramentas p/ uso manual,
 NÃO utilizar com equipamento pneumático)



cód.: Suporte 27048

CÓD.	MED.	CÓD.	MED.
G-100	6X1/2"	G-100	13X1/2"
G-100	8X1/2"	G-100	14X1/2"
G-100	10X1/2"	G-100	17X1/2"
G-100	12X1/2"	G-100	19X1/2"

Kg 1.65



CR 99
Extensão longa (730mm) c/ encaixe de 1/2"

■ 1/2" □ 1/2"

Kg 0.97

NIQUEL CROMADO **Guerra 100**
Forjados Especiais

CR 200
Alavanca tensionadora (500 mm) com encaixe de 1/2" com extensão de alavanca (200mm) para uso com soquetes ou chaves intercambiáveis (CR 201)

■ 1/2" □ 1/2" □ 1/2"

Kg 1.40

G100 500
Cabo em "L" (250mm) com encaixe de 1/2" nas duas pontas

■ 1/2" □ 1/2"

Kg 0.50

NIQUEL CROMADO **Guerra 100**
Forjados Especiais

G100 502
Extensão longa (400mm) c/ encaixe de 1/2" e □ 1/2" (acompanha cabo auxiliar)

■ 1/2" □ 1/2"

Kg 0.88

NIQUEL CROMADO

G100 505
Cabo em "L" (230mm) com encaixe de 1/2"

■ 1/2"

Kg 0.40

Guerra 100 **NIQUEL CROMADO**
Forjados Especiais

G100 525
Cabo T com encaixe móvel de 1/2"

■ 1/2"

Kg 0.40

NIQUEL CROMADO

G100 502-A
Cabo "T" com encaixe de 1/2" (300 mm) Cabo deslizante

□ 1/2" ■ 1/2"

Kg 0.55

Guerra 100 **NIQUEL CROMADO**
Forjados Especiais

CR 176
Chave de aperto angular

■ 1/2"

Kg 0.24

CR 99-A
Extensão curta (70mm) c/ encaixe de 1/2"

■ 1/2"

□ 1/2" Kg 0.12

G100 512
Adaptador ■ 1/2" X 19mm sextavado

Kg 0.05

G100 512 A
Multiplicador de posições de aperto ■ 1/2" x □ duplo quadrado regular estrelado 8 pontas - sextavado 24mm

■ 1/2" □

Kg 0.16

NIQUEL CROMADO **Guerra 100**
Forjados Especiais

1.3

Soquetes Especiais 3/4"

SOQUETE SEXTAVADO LONGO PARA RODAS, AUTOMÓVEIS E UTILITÁRIOS 3/4"



cód.: Suporte 27012



cód.: Suporte 27013



cód.: Suporte 27013

(Avulso ou jogo c/ suporte)

CÓD.	MED.	CÓD.	MED.
G-100	17X3/4"	G-100	22X3/4"
G-100	19X3/4"	G-100	23X3/4"
G-100	21X3/4"	G-100	24X3/4"

Kg
2.95



Kg
2.45

CÓD.	MED.
G-100	27X3/4"
G-100	30X3/4"
G-100	32X3/4"
G-100	33X3/4"

Kg
1.95

CÓD.	MED.
G-100	34X3/4"
G-100	36X3/4"
G-100	38X3/4"

Ferramenta p/ uso manual, NÃO utilizar com equipamento pneumático.

Utilizar com G100-501, G100-501 A e G100-504 para rodas de automóveis e utilitários

1.4

Cabos e Extensões 3/4"

G100 504

Cabo em "L" (400mm) com encaixe de 3/4"



3/4"

Kg
1.55



G100 501

Extensão longa (500mm) c/ encaixe de 3/4" e furo passante (multifuncional)
Não utilizar c/ máquina pneumática

3/4"



3/4"

Kg
1.65



G100 501 A

Extensão curta (250mm) c/ encaixe de 3/4" e furo passante (multifuncional)
Não utilizar c/ máquina pneumática

3/4"



3/4"

Kg
0.85



G100 525 A

Cabo T com encaixe móvel de 3/4" X 500mm



Kg
1.45



Linha Borracharia Sextavado

1.5

Chaves de Roda



CÓD.	MED.	Kg	CÓD.	MED.	Kg
G-100	17x19	1.50	G-100	27x32	2.10
G-100	19x24	1.40	G-100	27x36	1.95
G-100	21x38	2.20	G-100	27x33	2.10
G-100	22x24	1.50	G-100	30x32	2.10
G-100	24x27	1.60	G-100G	30x33	1.95
G-100	27x29	1.95	G-100	32x33	2.15
G-100	27x30	2.10			



Chave longa (500mm) com encaixe sextavado com medidas diferentes em cada extremidade
Forjada em Aço Especial
Usinadas com paredes de alta resistência e cabeças profundas



NOVO

G-100 17x19 com cabo

Manípulo e Cabos de Força 1.6

G100 503

Cabo de força (1200mm) para chave de rodas (maciço) forjado - zincado

Kg
4.40



● 1"



G100 503 A

Cabo de força (600mm) para chave de rodas (maciço) forjado - zincado

Kg
2.15



● 1"

G100 519

Tubo prolongador (mão de força) (1000mm) zincado

Kg
2.65



○ 1"

G100 503 B

Manípulo (400mm X 3/4") para chave de rodas zincado

Kg
1.10



● 3/4"

Chave de Roda Cruz 1.7

CHAVE CRUZ 3 bocas

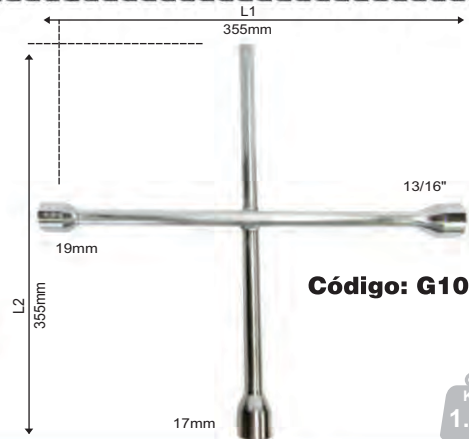

Código: G100 3B



Kg
1.00

CHAVE CRUZ 4 bocas

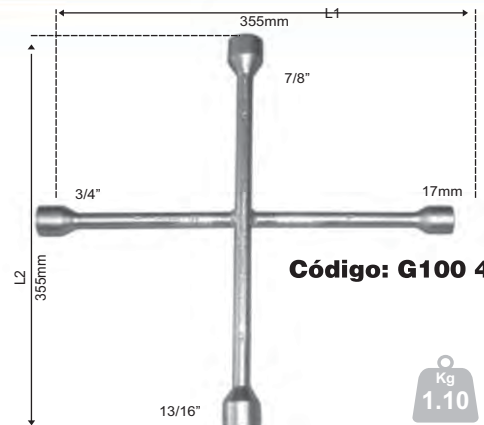

Código: G100 4B

Kg
1.10

CHAVE CRUZ PROFISSIONAL 4 bocas

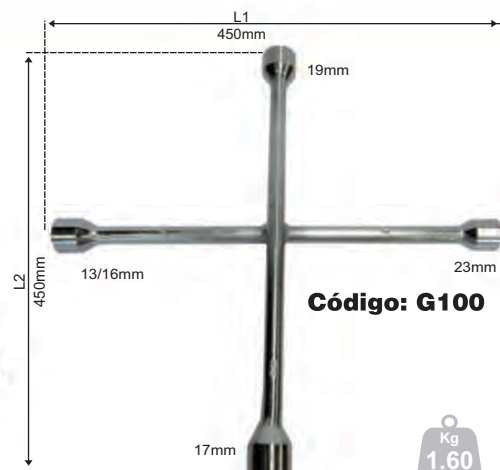

Código: G100

Kg
1.60



1.8 Chave de Rodas "L" c/ Espátula

G100 L

Forjada com encaixe sextavado em uma das extremidades com parede fina de alta resistência.

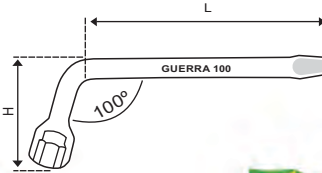

CÓD.	MED.	Kg
G-100 L17	100x350	0.52
G-100 L19	100x350	0.52
G-100 L21	120x400	0.68
G-100 L22	120x400	0.70
G-100 L23	120x400	0.70



1.9

Espátulas

Espátula Redonda tipo alavanca

G100 509 — 610 mm

G100 510 — 470 mm

G100 511 — 280 mm

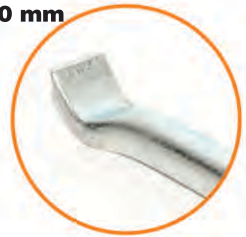

Espátula Chata Perfil I



G100 506 — 600 mm

G100 507 — 460 mm

G100 508 — 240 mm



Espátula Chata Tipo Carreteiro (perfil liso) Alta Resistência

G100 520 — 600 mm

G100 521 — 460 mm

G100 522 — 240 mm



G100 517 - Formula Truck

Espatula forjada, maciça, sem emendas para (des)montar pneus (utilitários). Recomenda-se utilização c/ 2 pçs. Mais a trava G100 516.
Med.: 1"x1000mm



Kg
3.95



G100 518 - Tipo Michelin

Kit de Espatulas tipo Michelin (3 Pçs) (des)montagem de pneus sem camara (Utilitários)



Kg
5.20

G100 516

Trava para pneus sem camara



Kg
0.18

G100 526

Jogo de espátulas (2) para (des)montar pneus sem camara (utilitários) acompanha trava G100-516



FORJADA (sem emendas)
Aço maciço 7/8" X 960mm



Kg
6.20

G100 527

Alavanca tipo espátula (des)montar pneu sem camara de utilitário
Aço Forjado maciço (1.1/4 X 1180mm)
Recomenda-se a utilização com auxílio de: G100-517 ou G100-520



Kg
7.45



G100 513

Destalonador de talão



Kg
12.17



G100 514

Espatula para desmontar pneus sem camara (Caminhões)



Kg
7.35



G100 515

Espatula para montar pneus sem camara (Caminhões)



Kg
3.40



→
 Ø 1/2"
 para uso
 maquina
 pneumática



G100 524

Dispositivo para descolar pneus de veiculos de passeio (aro 15a 22") a fim de soltar e colocar a cinta da blindagem
 Uso Manual ou com máquina pneumática.

Acompanha espátula G100 521



↑
 para uso manual

Kg
 24.60



CR 501

Cavalete Pequeno (p/ sustentação de veiculos) 300/500mm - 2 Ton.

Kg
 2.82



CR 503

Cavalete grande para veiculos pesados (utilitários) 500 a 700 mm 4 ton.

Kg
 7.30

CR 350

Alicate balanceador



Kg
 0.38

G100 523

Ferramenta para desamassar borda de rodas de ferro de veiculos de passeio



Kg
 1.10



SACA POLIAS

2 Garras

CÓD.	ABERTURA	PROFUNDIDADE	
G-102	110mm	85mm	0.47
G-202	120mm	120mm	0.60

3 Garras

CÓD.	ABERTURA	PROFUNDIDADE	
G-103	110mm	85mm	0.60
G-203	120mm	120mm	1.30



Jogo de Garras para reposição

Kg
0.19



Kg
0.45

G 102/3 G-A

G 202/3 G-A



CR 469

Extrator de polias
(Multifuncional) Abertura: 48mm - 82mm
Rosca M14 x 100mm Diâmetro externo: 100mm
Extração por garras ou parafusos M6 ou M8

MINI EXTRATORES



2 Garras

CÓD.	ABERTURA	PROFUNDIDADE	
G40-2	40mm	40mm	0.22
G60-2	60mm	60mm	0.25

3 Garras

CÓD.	ABERTURA	PROFUNDIDADE	
G40-3	40mm	40mm	0.27
G60-3	60mm	60mm	0.29



Polia

Jogo de Garras para reposição

Kg
0.06



Kg
0.09

G 40/2/3 G-A

G 60/2/3 G-A

* Jogos ou Avulsas
Suportes Vendidos separadamente

Uso manual (NÃO usar com ferramenta pneumática)

TORX® é marca registrada da Camcar Textron - Inc. Usa.

Torx 1.13



cód.: Suporte 27003

CR 28 L - JOGO

Jogo de 8 peças (ou unitário) de chave "L",
tipo Biela TORX E6, E8, E10, E12, E14, E18, E20, E24



Kg
2.46



cód.: Suporte 27048

Ø 1/2

CR 28 S - JOGO

Jogo c/ 08 (ou unitário) pçs de soquetes
especiais longo (75mm)
TORX E6, E8, E10, E12, E14, E18, E20, E24

Kg
1.32

BOCA TORX®	mm
E 6	5,74
E 8	7,52
E 10	9,42
E 12	11,17
E 14	12,90
E 18	16,70
E 20	18,45
E 24	22,16



cód.: Suporte 27049

CR 31 - E CANHÃO TORX®

Jogo c/ 04 pçs (ou unitário) de chave
tipo canhão TORX® E6, E8, E10, E12

Kg
0.68



CR 29TX T - JOGO

Jogo c/ 09 pçs (ou unitário) de chave tipo "T" TORX T20, T25, T27, T30, T40, T45, T50 (Uso manual), T55, T60 (uso de catraca com encaixe de 1/2") Não utilizar p/ aperto em cabeçotes ou cabos para aumentar torque

Kg
2.18

cód.: Suporte 27007



CR 29TX S - Ø 1/2 JOGO

Jogo c/ 09 pçs (ou unitário) de chave soquete TORX (60mm) T20, T25, T27, T30, T40, T45, T50, T55, T60, encaixe de 1/2". (Não utilizar para aperto em cabeçotes)



cód.: Suporte 27009

Kg
0.80

PONTA TORX®	mm
T 20	3,86
T 25	4,43
T 27	4,99
T 30	5,52
T 40	6,65
T 45	7,82
T 50	8,83
T 55	11,22
T 60	13,25



CR 31TX - PONTA TORX®

Jogo c/ 07 pçs (ou unitário) de chave tipo fenda TORX T20, T25, T27, T30, T40, T45, T50



cód.: Suporte 27010

Kg
0.80

CR 29TX - L - JOGO

Jogo de 09 pçs (ou unitário) de chave tipo "L" longa 200mm TORX T20, T25, T27, T30, T40, T45, T50, T55, T60



cód.: Suporte 27008

Kg
1.30

1.14 Chave Multidentada (Perfil dodecagonal externo)

Uso manual (Não usar com ferramenta pneumática)



CR 73 / M6

Chave tipo soquete longa (90mm), multidentada de 6mm 0.10kg



CR 73-A / M6

Chave "L" longa (200mm) multidentada de 6mm 0.10kg



CR 72 / M8

Chave tipo soquete longa (90mm), multidentada de 8mm 0.10kg



CR 72-A / M8

Chave "L" multidentada de 8mm extra longa (260mm) 0.15kg



CR 71 / M10

Chave tipo soquete longa (90mm) multidentada de 10mm 0.12kg



CR 71-A / M10

Chave "L" longa (200mm) multidentada de 10mm. 0.12kg



CR 30 / M12

Chave tipo soquete longa (90mm) multidentada de 12mm 0.12kg



CR 30-A / M12

Chave tipo "L" longa (200mm) estriada de 12mm 0.14kg



CR 89 / M14

Chave tipo soquete longa (90mm), multidentada de 14mm 0.12kg



CR 89-A / M14

Chave "L" longa (200mm) multidentada de 14mm Usos Diversos 0.13kg



CR 185

Chave tipo soquete longo (90mm), multidentada de 16mm, para parafusos do volante do motor Mercedes OM, 904/906 0.16kg



CR 185 A

Chave "L" longa (200mm) multidentada de 16mm Usos Diversos 0.39kg

Chave Soquete Hexagonal (Allen) 1/2" 1.15

Uso manual (Não usar com ferramenta pneumática)



□ 1/2

CR 74 / 5mm
Chave soquete longa (100mm)
0.10kg



□ 1/2

CR 59 / 6mm
Chave soquete longa (100mm)
0.10kg



□ 1/2

CR 59-A / 6mm
Chave soquete longa (140mm)
0.12kg



□ 1/2

CR 59-C / 6mm
Chave tipo soquete curto (40mm)
0.08kg



□ 1/2

CR 54 / 7mm
Chave soquete longa (100mm)
0.10kg



□ 1/2

CR 75 / 8mm
Chave soquete longa (100mm)
0.10kg



CR 76 / 10mm
Chave soquete longa (140mm)
0.12kg



□ 1/2

CR 77 / 12mm
Chave soquete longa (140mm),
0.14kg

Troca de Óleo 1.16



■ 8mm

CR 271
Chave com ponta quadrada de 8mm. Sextavado para encaixe de 1/2" comprimento total 40mm
0.04kg



■ 10mm

CR 272
Chave com ponta quadrada de 10mm. Sextavado para encaixe de 5/8" comprimento total 40mm
0.06kg



■ 1/2

CR 273
Chave com ponta quadrada de 1/2". Sextavado para encaixe de 5/8" comprimento total 40mm
0.07kg



● 6mm

CR 274
Chave com ponta allen de 6mm. Sextavado para encaixe de 1/2" comprimento total 40mm
0.04kg



● 8mm

CR 275
Chave com ponta allen de 8mm. Sextavado para encaixe de 1/2" comprimento total 40mm
0.04kg



● 10mm

CR 276
Chave com ponta allen de 10mm. Sextavado para encaixe de 5/8" comprimento total 40mm
0.06kg



● 12mm

CR 277
Chave com ponta allen de 12mm. Sextavado para encaixe de 5/8" comprimento total 40mm
0.08kg



● 14mm

CR 278
Chave tipo inserto hexagonal de 14 x 5/8" comprimento total 40mm
0.10kg



● 17mm

CR 279
Chave tipo inserto hexagonal de 17 x 3/4" comprimento total 40mm
0.08kg



● 19mm

CR 280
Chave tipo inserto hexagonal de 19 x 3/4" comprimento total 40mm
0.10kg



CR 295
Chave "T" Curta (140mm) com soquete fixo quadrado de 8mm.
0.28kg



CR 27072 JG
Jogo de Bits (11 pçs) (CR 271 a CR 280 + CR 160 A) (com suporte)
0.76kg



CR 160 A
Chave com ponta multidentada de 16mm (com guia de segurança) VW G5 / Audi A3 / Passat / Golf / Polo / Fox
0.05kg



CR 295 A
Chave "T" Curta (140mm) com soquete fixo quadrado de 10mm.
0.28kg



● 1/2" ■ 8mm

CR 271 A
Chave soquete com encaixe de 1/2" de 8 posições
Ponta quadrada de 8mm (comprimento 50mm)
0.08kg



● 1/2" ■ 10mm

CR 272 A
Chave soquete com encaixe de 1/2" de 8 posições
Ponta quadrada de 10mm (comprimento 50mm)
0.07kg



● 1/2" ● 12mm

CR 277 A
Chave soquete com encaixe de 1/2" de 8 posições
Ponta allen de 10mm (comprimento 50mm)
0.08kg



● 1/2" ● 14mm

CR 278 A
Chave soquete com encaixe de 1/2" de 8 posições
Ponta allen de 14mm (comprimento 50mm)
0.09kg



● 1/2" ● 17mm

CR 279 A
Chave soquete com encaixe de 1/2" de 8 posições
Ponta allen 17mm (comprimento 50mm)
0.09kg



CR 470 JG
Jogo de soquetes (6 pçs) (CR 271 A / 272 A / 277 A / 278 A / 279 A e 100 512 A) (com suporte 27006)
0.76kg



G100 512 A
Multiplicador de posições de aperto  x  duplo quadrado regular estrelado 8 pontas - sextavado 24mm

 
0.16kg

1.17 Saca Filtros - Óleo e Combustível



CR 88
Veículos pesados: MB Sprinter e outros veículos que possuem filtros na posição horizontal.
Abertura máxima 147mm  1.11kg



CR 88 D
Universal (uso manual)
Abertura máxima 130mm  0.40kg



CR 88 i
Cinta metálica Abertura: 60 a 106 mm (uso universal)  0.34kg



CR 88 A
Universal (Abertura máxima 147mm)
Usar com extensão 1/2"
 0.38kg



CR 88 i (A)
Cinta metálica avulsa do saca filtro CR 88-i  1.11kg



CR 88 C
76,5mm - 12 aletas
Renault 1.6 - Peugeot e Citroën  0.25kg

CR 88 E
67mm - 6 aletas
Renault 1.0 - Peugeot  0.20kg



CR 88 B
74 mm - 8 FACES  0.25 kg
Marea(todos) Brava 1.8, Stillo 2.4, Alfa 145, Alfa 156 e Alfa Twin Spark (filtro 46808398)  0.50 kg

CR 88 G
64mm - 14 FACES
Universal HONDA / Corolla/ Toyota / Nissan  0.20 kg

CR 88 L
66,6mm - 14 FACES
HYUNDAI HB20 1.0  0.21 kg

CR 88 P
86mm - 16 FACES
tampa do filtro de Óleo (refil) dos veículos BMW (série 3) Volvo motor Bt4204 2014...  0.30 kg

CR 88 H
75mm - 14 FACES
Citroën, Fiat, Peugeot E Subaru Obs: (Filtro W7 Multi 20 MANN  0.21 kg

CR 88 M
92mm - 15 FACES
HYUNDAI: HR / KIA 2500  0.39 kg

CR 88 Q
74mm - 15 FACES
Citroën/ Peugeot motor 1.2 Pure Tech - Cod. filtro: 1109  0.30 kg

CR 88 F
74mm - 14 FACES
MB SPRINTER 311/312 (CDI) e MB 715 ACCELO E (OM-611 E 612) Toro/ Freemont/ Compass (2.4)  0.26 kg

CR 88 J
80mm - 15 FACES
HYUNDAI: HB20 1.6 / I30 / IX35 / Elantra / Sonata / Tucson / Santa Fé 2.7 e 2.4  0.25 kg

CR 88 N
98,3mm - 15 FACES
TOYOTA Hilux até 2005 e Prado até 2014  0.47 kg

CR 88 S
76mm - 15 FACES
Cod. Filtro Fram: Ph4701 / 2870B / 10905 / 4703 / 10907 / 5566 / 10906 e similares com as mesmas medidas  0.30 kg

CR 88 K
74mm - 14 FACES
VW filtro (W719/45) Geração V e VI (inclusive motor TSI)  0.25 kg

CR 88 O
72,5mm - 14 FACES
TOYOTA Hilux 2006 em diante  0.25 kg



CR 88 R
74mm ou 64 mm - 14 FACES
Multifuncional: Honda, Nissan, Mitisubishi, Suzuki, (Toyota - refil Corolla)



CR 314
Chave estriada de 27mm para o Refil da tampa do filtro de óleo dos veículos: PEUGEOT e CITROËN 10.0 1.6 2013...  0.11 kg



CR 289
Chave estriada de 36mm c/ encaixe p/ cabo de 1/2" p/ filtro de óleo dos motores Fiat: E-Torq MWM NGD 3.0  0.12 kg



CR 302
Chave estriada de 32 mm para o Refil da tampa do filtro de óleo da motor GM - ECOTEC 2.4  0.14 kg



CR 375
Chave estriada de 36 mm comprimento de 235mm x 30" para soltar a tampa do filtro de óleo do motor N13- BMW / MINI COOPER.  0.26 kg



CR 354
Ferramenta para soltar e apertar a tampa plástica ranhurada do refil do filtro de combustível: BOXER / JUMPER / DUCATO 2.3 (2010...)  0.77 kg



CR 05
Chave para retirar a trava de fixação do filtro de combustível  0.10 kg



CR 12 A
Alicate p/ conexões de linha de combustíveis, filtros e sistema de injeção  0.31 kg



CR 12 B
Alicate c/ espessador p/ retirar o conector do filtro de combustível e sistema de injeção  0.38 kg



CR 12 D
Alicate para retirar o conector (Pop-top) do sistema de combustível  0.30 kg



CR 464
Chave tipo cachimbo comprimento 220mm com sextavado de 29 mm para as porcas dos bujões do carter: D10/D20/D40/BLAZER Diesel  0.39 kg



CR 465
 0.46 kg
Chave com formato"S" medidas 14 x 17 mm (sextavado interno) para bujão do carter Honda(17mm) Toyota(14mm)



CR 466
 0.45 kg
Chave com formato"S" medidas 14 x 16 mm (Quadrado interno) para bujão câmbio CHEVROLET: D20, D40, GMC 6-100, GMC 6-150, SILVERADO, S10 96 A 00.



CR 467
 0.45 kg
Chave com formato"S" medidas 13 x 15 mm (sextavado interno) para bujão de carter e câmbio (Linha Ford)



CR 468
 0.45 kg
Chave com formato"S" medidas 19 x 21 mm (sextavado interno) para bujão de carter e câmbio (Linha VW)

CR 02

Alicate com ponta móvel para abraçadeiras elásticas das mangueiras de água e ar condicionado

📏 0.34 kg

CR 02 A

Alicate com ponta móvel com INCLINAÇÃO DE 30° para abraçadeiras elásticas das mangueiras de água e ar condicionado

📏 0.34 kg

CR 06

Alicate para abraçadeiras (trava e destrava) da linha FIAT

📏 0.22 kg

CR 06 Super

Alicate para abraçadeiras (trava e destrava - FIAT / GM)

📏 0.31 kg

CR 10 A

Alicate para retirar os supressores dos cabos das velas

📏 0.34 kg

CR 10 A Super

Alicate extra longo (360mm) para retirar os supressores dos cabos das velas

📏 0.44 kg

CR 12

Alicate para abraçadeiras das mangueiras de água.

📏 0.34 kg

CR 12 C

Alicate para instalar a bucha da caixa da direção hidráulica Mod. VS e RW utilizado também para chicotes e mangueiras

📏 0.34 kg

CR 13

Alicate para retirar os retentores das guias de válvulas.

📏 0.30 kg

CR 161

Alicate para fixar abraçadeiras tipo "orelhas" ou "perma quick", usadas em sistema de refrigeração, filtros, linhas de vácuo e transmissão.



📏 0.46 kg

CR 232

Alicate Especial para Colocar as Mangueiras do Sistema de Alimentação de Combustível. (Engate Rápido) K C - Quick Conector

📏 0.60 kg

CR 112

Alicate especial para sacar o Mancal de ajuste da cremalheira. (Direção hidráulica) - DHB

📏 0.18 kg

CR 351

Alicate 8" para travas de homocinéticas

📏 0.19 kg

CR 352

Alicate para travas de homocinéticas e câmbio 11"

📏 0.46 kg

Chaves para Vela 1.19

∅ 1/2

**CR 21**

Chave para velas (longa 150 mm)

📏 0.44 kg

∅ 1/2

**CR 21-Art.**

Chave articulada para velas (21mm)

📏 0.22 kg

∅ 1/2

**CR 21-L**

Chave para velas, (extra longa 250 mm)

📏 0.70 kg

∅ 1/2

**CR 23**

Chave para velas (curta 95mm) parede fina (16 mm)

📏 0.18 kg

∅ 1/2

**CR 23-L**

Chave para velas (longa 200mm) c/ cabo auxiliar (16 mm)

📏 0.50 kg

∅ 1/2

**CR 23-LA**

Chave de velas (extra longa 330mm) (16 mm)

📏 0.52 kg

∅ 1/2

**CR 23-LB**

Chave de velas (longa 195mm) (16 mm) parede fina

📏 0.27 kg

∅ 1/2

**CR 23-Art.**

Chave articulada para velas (16mm)

📏 0.22 kg



CR 82

Chave para velas especial para vela do 3º cilindro da S10 / Blazer (4.3 V6) (16 mm)

0.45 kg



1/2

CR 128

0.37 kg

Chave para velas (extra longa 300mm) (14 mm sextavado) Renault - Clio 1.0 16V de 2001.../Peugeot 206 1.0 16V



1/2

CR 128 B

0.22 kg

Chave para velas (longa 195mm) (14 mm sextavado)

CR 128 A



Chave de velas 14mm extriada (Curta 80mm) encaixe 3/8" Peugeot / Citroën - Motor THP/ BMW

0.07 kg

1.20 Encolhedores de Molas



1/2

CR 92

2.62 kg

Compressor de molas dianteiras (garras simples) Uso c/ catraca ou máquina pneumática, encaixe de 1/2". Jogo c/ 02 pçs.



1/2

CR 93

2.75 kg

Compressor de molas dianteiras (garras duplas) Uso com catraca ou máquina pneumática. encaixe de 1/2". Jogo c/ 02 pçs.



1/2

CR 94

4.40 kg

Compressor de molas dianteiras (suspensão MCPERSON) Uso com catraca ou máquina pneumática.

com rolamento de alívio



CR 253

Compressor de molas da suspensão traseira

VW: Gol, Voyage, Parati, Saveiro Jogo c/ 02 pçs.

0.45 kg



CR 11013

Dispositivo giratório para fixar torre da suspensão à bancada de trabalho.

4.48 kg

CR 93 A

0.51 kg

Fuso roscado para reposição das ferramentas CR 92 e CR 93 (Bucha e Tampa)

CR 94 A

0.44 kg

Fuso roscado para reposição da ferramenta CR 94 (com rolamento)



1/2

CR 171

Encolhedor de molas (suspensão MCPHERSON) para uso em bancadas. Uso manual ou com máquina pneumática.

8.17 kg



CR 300 Manual

Compressor de molas de suspensão dianteira MCPHERSON. Molas com diâmetro entre 90 e 185mm com espessura até 19mm. Permite que a torre da suspensão fique "livre" comprimindo somente a mola, facilitando a remoção dos componentes necessários. Acompanha 8 garras intercambiáveis (Atenção: este equipamento deve ser cuidadosamente fixado em parede ou suporte especial)

32.0 kg

Garantia e Assistência técnica

ATENÇÃO



Utilize sempre equipamentos de segurança ao manusear estes equipamentos



1/2

CR 173

Encolhedor de molas (suspensão MCPERSON) para uso em bancadas. Uso manual ou com máquina pneumática.

6.38 kg

*Foto Ilustrativa

*Foto Ilustrativa



CR 101
Martelo deslizando, especial para extrair homocinéticas. **3.27 kg**



CR 104
Ferramenta c/ dispositivo ajustável para retirar a pista do rolamento do cubo de roda. Até Ø 60mm. (Usar com prensa hidráulica). **3.25 kg**



CR 104 A
Jogo de castanhas para reposição CR 104 **0.23 kg**



CR 374 Extrator Universal para sacar o eixo homocinético sem sofrer impactos **2.07 kg**



CR 126
Extrator de prisioneiros de: 1/2" a 3/4" **0.62 kg**



CR 162
Extrator para rolamentos de alternadores e dinamos com diâmetro externo de 25 a 47mm **2.44 kg**

(acompanha 08 castanhas)



CÓDIGO DOS ROLAMENTOS E CASTANHA A SER UTILIZADA

6303	⊗	6201	⊗
6203	⊗	6200	⊗
6202	⊗	6000	⊗

As castanhas com os códigos 4V e 3MM são utilizadas nos rolamentos: 6203 (Vectra) e 6202 (alternadores Magneti Marelli)



CR 180 Extrator de rolamentos com 2 garras intercambiáveis. (Acompanha 2 fusos: fuso roscado 170mm p/ extração pelo exterior e fuso 470mm p/ extração por impacto). **3.69 kg**

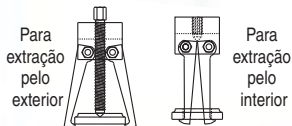

CR 180 A

Garra avulsa da ferramenta CR 180 (par) **0.39 kg**



CR 126 A
Extrator de prisioneiros de: 1/2" a 3/4" **0.29 kg**



CR 26033
Extrator de rolamentos à percussão (UNIVERSAL) **2.02 kg**



CR 26033-A
Garra avulsa da ferramenta CR 26033 (par) **0.13 kg**



CR 26034
Jogo c/ 8 extratores de rolamentos interno (tipo pinça) e 1 martetele p/ extração à percussão (rosca de 1/2" - 9 pçs) **4.70 kg**



CR 26043
Martetele

Unitários

CR 26035 8-10mm CR 26036 10-12mm CR 26037 12-14mm CR 26038 15-17mm CR 26039 17-20mm CR 26040 20-24mm CR 26041 25-29mm CR 26042 30-32mm (MEDIDAS INTERNAS) **1.42 kg**



CR 257
Ferramenta para retirar: retentores, anéis, capas de rolamentos e tampões (Obs.: Não usar a ferramenta para bater) **0.43 kg**

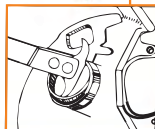

CR 26002
Cabo longo instalador de rolamentos (300mm) **0.80 kg**



CR 26003
Cabo curto instalador de rolamentos (120mm) **0.47 kg**



Instalador de rolamentos e retentores

CR 26001

Jogo de ferramentas para instalação de rolamentos com 30 pçs: 2cabos (longo-curto) 16 guias e 12 buchas (contém: CR 26002 a 26032) **7.37 kg**



CR 26004
Instalador de rolamentos (guia) 10mm **0.01 kg**



CR 26005
Instalador de rolamentos (guia) 12mm **0.01 kg**



CR 26006
Instalador de rolamentos (guia) 13mm **0.01 kg**



CR 26007
Instalador de rolamentos (guia) 14mm **0.01 kg**



CR 26008
Instalador de rolamentos (guia) 15mm **0.01 kg**



CR 26009
Instalador de rolamentos (guia) 16mm **0.02 kg**



CR 26010
Instalador de rolamentos (guia) 17mm **0.02 kg**



CR 26011
Instalador de rolamentos (guia) 19mm **0.02 kg**



CR 26012
Instalador de rolamentos (guia) 20mm **0.03 kg**



CR 26013
Instalador de rolamentos (guia) 22mm **0.03 kg**



CR 26014
Instalador de rolamentos (guia) 25mm **0.04 kg**



CR 26015
Instalador de rolamentos (guia) 28mm **0.06 kg**

CR 26016
Instalador de rolamentos (guia) 30mm
0.06 kg

CR 26017
Instalador de rolamentos (guia) 35mm
0.10 kg

CR 26018
Instalador de rolamentos (guia) 40mm
0.13 kg

CR 26019
Instalador de rolamentos (bucha) 22x24mm
0.35 kg

CR 26020
Instalador de rolamentos (bucha) 24x26mm
0.45 kg

CR 26021
Instalador de rolamentos (bucha) 28x30mm
0.70 kg

CR 26022
Instalador de rolamentos (bucha) 32x35mm
0.10 kg

CR 26023
Instalador de rolamentos (bucha) 37x40mm
0.15 kg

CR 26024
Instalador de rolamentos (bucha) 40x42mm
0.18 kg

CR 26025
Instalador de rolamentos (bucha) 42x47mm
0.20 kg

CR 26026
Instalador de rolamentos (bucha) 45x50mm
0.24 kg

CR 26027
Instalador de rolamentos (bucha) 52x55mm
0.32 kg

CR 26028
Instalador de rolamentos (bucha) 62x68mm
0.49 kg

CR 26029
Instalador de rolamentos (bucha) 72x75mm
0.64 kg

CR 26030
Instalador de rolamentos (bucha) 78x90mm
0.81 kg

CR 26032
Instalador de rolamentos (guia) 32x50
0.30 kg

CR 220 TOP
Extrator de: Rolamentos, Polias e Engrenagens. (Uso Universal)
(Peças avulsas ou jogo com 14 componentes - com caixa)

220/01
Fuso c/ rosca M16x1.5x97mm
0.15 kg

220/02
Fuso c/ rosca M16x1.5x200mm
0.32 kg

220/03
Apoio com 4 regulagens compr. 90x90mm
0.53 kg

220/04
Apoio em "Y" c/ 4 regulagens compr. 90x90x90mm
0.76 kg

220/05
Acessório p/ uso em prensa
0.73 kg

220/06
Acessório p/ proteger pontas de eixo
0.02 kg

220/07
Jogo de 3 garras p/ extração interna ou externa c/ 3 regulagens compr. 150mm (acompanha jogo de parafusos e porcas)
0.66 kg

220/10
Par de extensores de 222mm c/ regulagem de rosca de 1/2x1/2 em 150mm, acompanha porca reguladora de altura, porca e arruela p/ fixação (usar c/ item 13 e 14)
0.64 kg

220/11
Par de extensores de 216mm c/ regulagem de rosca de 1/2x3/8 em 150mm, acompanha porca reguladora de altura, porca e arruela p/ fixação (usar c/ item 12)
0.64 kg

220/15
Jogo de 3 garras p/ extração interna ou externa com 3 regulagens comprimento: 250 mm
1.20 kg

Jogo - 24 peças
12.74 kg

220/08
Jogo de 2 garras p/ extração do volante da direção
0.20 kg

220/09
Jogo de 3 garras p/ extração interna de rolamentos
0.29 kg

Extrator 220/12
de 20 a 50mm
0.60 kg

Extrator 220/13
de 50 a 75mm
1.38 kg

1.22 Elétrica

CR 44
Chave para sondas lambda de veículos equipados com catalisador, 1/2", sextavado de 22mm. Comp.: 105mm
0.29 kg

CR 50
Chave estriada para sensor de temperatura de água / óleo (19 mm)
0.20 kg

CR 50-A
Chave sextavada para sensor de temperatura de água / óleo (21 mm)
0.24 kg

CR 291
Chave sextavada de 24mm vazada para porca da polia do alimentador BOSCH
0.22 kg

CR 44 A
Chave para sondas lambda de veículos equipados com catalisador, encaixe 1/2", sextavado de 22mm (CURTA) Comprimento: 48mm
0.17 kg

CR 51
Chave para extrair cebolão do radiador sextavado de 30mm, encaixe de 1/2".
0.17 kg

CR 143
Chave especial multidentada para polia com catraca dos alternadores INA/Valeo/Bosch (usar c/ 29TXL T50 ou CR 71)
0.09 kg

CR 12007 A
Jogo de grampos (2pçs) bloqueio das mangueiras de combustível, vacuô e freio. (capacidade 20 mm)
0.16 kg

CR 193
Ferramenta para sacar buchas (metálicas) bombas injetoras, dinamos, alternadores, motores de partidas e outros (automóveis e caminhões) acompanha: 2 adaptadores e 3 pinças
0.58 kg

CR 254
Chave de fenda (flexível) 1/8" x 250 mm para regulagem da mistura da marcha lenta do carburador
0.04 kg

CR 193-A
Jogo de pinça Avulsa 3 peças
0.08 kg

CR 318
Chave soquete longo (10mm) com sextavado externo (17mm) p/ polias de alternadores (Denso) com sistema roda livre
0.14 kg



CR 84

Ferramenta para soltar as tampas (plásticas ranhuradas) do conjunto bóia-bomba de combustível e bombonas (regulagem de abertura de 45 a 200 mm)

🏠 0.73 kg



CR 84 A

Ferramenta para retirar e colocar o anel metálico (1K0201305) que fixa a bomba elétrica de combustível ao tanque VW: Jetta, Golf, Eos, CC, Polo, Virtus, T-Cross, Tiguan, Toureg

🏠 0.38 kg



CR 84 B

Ferramenta para retirar e colocar o anel metálico Fiat Toro, Renegade, Compass, New Tucson, Mercedes, Volvo

🏠 0.50 kg

Funileiro / Tapeceiro 1.23



CR 80

Marreta Dinâmica: Para funileiro com 05 regulagens

🏠 9.40 kg



CR 215

Ferramenta especial para sacar grampos (Tapeçaria). (115 mm)

🏠 0.07 kg



CR 215-A

Ferramenta especial para sacar grampos (Tapeçaria). (195 mm)

🏠 0.18 kg



CR 215 B

Jogo de espátulas plásticas (3pçs) para destacar acessórios de painéis, laterais de portas e outros.

🏠 0.10 kg

Freio 1.24



CR 40

Arrebiteadeira de bancada para lona de freio de automóveis.

🏠 2.63 kg



CR 213

Conjunto de ferramentas com 3 medidas de adaptadores para pressionar o êmbolo da pinça de freio a disco traseiro (rosca direita / rosca esquerda)

🏠 1.06 kg



CR 214 A

Ferramenta para comprimir o disco/ pistão para facilidade na substituição das pastilhas de freios

🏠 0.27 kg



CR 01

Reservatório (5") magnético (emborrachado) para lavar e concentrar pequenas peças e parafusos.

🏠 0.28 kg



CR 214

Ferramenta para abrir pinças de freio

🏠 0.45 kg

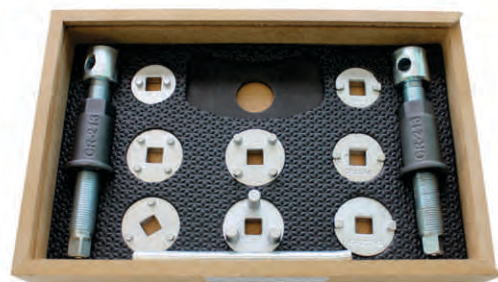

CR 213 TOP

Jogo de ferramentas para posicionar o êmbolo da pinça de freio a disco traseira

ROSCA DIREITA E ESQUERDA (COM 8 ADAPTADORES: 32, 35 e 40 MM, e + 5 MEDIDAS ESPECIAIS PARA OS VEICULOS IMPORTADOS)

🏠 1.80 kg

CR 213 Adaptadores avulsos



CR 213 A - (32mm)

🏠 0.04 kg

CR 213 B - (35mm)

🏠 0.05 kg

CR 213 C - (40mm)

🏠 0.06 kg

CR 213 D - (32mm)

🏠 0.03 kg

CR 213 E - (32mm)

🏠 0.05 kg

CR 213 F - (38 MM)

🏠 0.05 kg

CR 213 G - (40 MM)

🏠 0.06 kg

CR 213 H - (40mm)

🏠 0.08 kg

1.25 Escapamentos



CR 148
Alargador e modelador de cano de escapamento

1.36 kg



CR 148 A
Ferramenta para retirar o cano de escapamento encapsulado no silencioso (sem danificar)

0.37 kg

1.26 Equipamentos / Medição



CR 1003
Medidor e teste de compressão de cilindro.

Manômetro: 300 psi / 21 bar ou kgf/cm com capa protetora, engate rápido com alívio de pressão 10 adaptadores com conexão por rosca automóveis e motocicletas (NACIONAIS E IMPORTADOS)

1.92 kg

1	M10 X 1 - curto
2	M 12 X 1,25 - curto
3	M 14 X 1,25 - curto
4	M 12 X - longo
5	M 14 X 1,25 - longo
6	M 18 X 1,5 - curto
7	Adaptador de pressão
8	Tubo prolongador 200mm
9	Tubo prolongador 100mm
10	Adaptador de entrada



CR 1004
Teste da pressão da bomba de óleo, sistema hidráulico de direção e câmbio (acompanha 10 adaptadores) automóveis/ caminhões/ motocicletas (NACIONAIS E IMPORTADOS)

1.85 kg

MANOMETRO 21 BAR GLICERINA

1	1/8" NPT	
2	1/4" BSP	
3	3/8" NPT	
4	M 6 X 1	
5	M 10 X 1	
6	M 10 X 1	X 55mm
7	M 14 X 1,5	
8	M 16 X 1,5	
9	M 18 X 1,5	
10	COTOVELO	

ESPECIAL PARA CAMBIO AUTOMATICO



CR 1001 A
Medidor e teste de pressão e vazão simultânea da bomba elétrica de combustível

2 Manômetros de aço inox (4" escala de 0 a 14 BAR/200psi) e (62mm escala de 200L/H) com glicerina e capa protetora de borracha

Acompanha estojo especial

17 mangueiras numeradas

4.08 kg



CR 1007
Teste de arrefecimento. Realiza teste de radiadores e tampas dos reservatórios comuns e selados SISTEMA DE ENGATE RÁPIDO COM ALÍVIO

3 Tampas METÁLICAS para radiador comum: Nacional, Asiático e Ranger. 7 tampas de nylon (FUNÇÃO 2 em 1) Para as marcas: VW/FORD, GM, FIAT, BMW, GOLF, VW G3/G4. RENAULT, PEUGEOT, CITROEN, HYUNDAI

Manômetro de 30 libras com capa protetora

ACOMPANHA ESTOJO ESPECIAL COM REVESTIMENTO METÁLICO

3.87 kg



CR 07 S Rosca M14
CR 07 AS Rosca M12

Conjunto Relógio comparador com suporte

1.00 kg

Universal



CR 1008
Vacuômetro automotivo. 0 a 760 pol/Hg mmHg

0.29 kg



CR 1009
Vacuômetro automotivo. Duplo com registro 0 a 760 pol/Hg mmHg

0.73 kg

Suspensão 1.27

CR 43 0.12 kg
Chave de boca fixa (comp. 200 mm X 17 mm) 90 de curvatura e parede fina exclusivamente para soltar as porcas da bieleta (uso universal)

CR 72 A L 8MM 0.15 kg
Chave "L" multidentada de 8mm extra longa (260mm) para homocinética.

CR 125 0.85 kg
Ferramenta para colocar capa do rolamento

CR 119 1.70 kg
Estrator e colocador de rolamento (para uso em prensa)

CR 139 6.75 kg 140mm
Martelo de extração para cubo do eixo da roda dianteira (Universal) 4 e 5 furos

CR 139 A 3.08 kg
Ferramenta para extrair o cubo do eixo (Universal) (140mm) 4 e 5 furos

CR 139 B 0.78 kg
Fuso roscado (350mm) completo para substituição da ferramenta CR 139 A 40mm x 7/8" x 14 Fpp Unc

CR 150 1.10 kg
Ferramenta para (des)montar braço axial da caixa de direção $\square \frac{1}{2}$

CR 150 A 0.38 kg
Ferramenta para (des)montar braço axial da caixa de direção com encaixe de 1/2 abertura de 36 a 41mm

CR 150 B 0.56 kg
Ferramenta para (des)montar braço axial da caixa de direção com encaixe de 1/2 abertura de 41 a 48mm

CR 157 A 3.15 kg
Extrator de pista interna de rolamentos (uso no local) $\square \frac{1}{2}$

CR 157 B 0.72 kg
Fuso roscado (190mm) para reposição da ferramenta CR 157-A (acompanha jg de parafusos com esfera) 146mm x "x16 Fpp Unc- laminada

CR 174 2.13 kg
Ferramenta para extrair o cubo do eixo (120mm) 4 furos

CR 313 4.96 kg
Alavanca para a remoção de rótulas, pivôs, braços transversais e componentes da suspensão uso universal e versátil com 6 regulagens 2 adaptadores

CR 181 1.23 kg
Sacador universal para capas de rolamentos.

CR 234 0.12 kg
Ferramenta para "abrir" a manga de eixo da suspensão dianteira, a fim de soltar os amortecedores nos veículos: VW: Polo, Golf e Audi Ford: Fiesta e Escort, Citroen: C3

CR 237 0.81 kg
Espátula (tipo garfo) para "descolar" pivôs e terminais Uso Geral

CR 260 0.65 kg
Alicate para coifa de Homocinética abertura: 74 mm

CR 260 A 0.62 kg
Alicate para coifa de Homocinética abertura: 85 mm

CR 425 1.84 kg
Extrator de terminais de direção, (Uso universal) Abertura das garras: 55 a 110mm fuso roscado de 3/4" x 100mm

CR 425 A 0.45 kg
Garra avulsa CR 425

Válvulas - Motor 1.28

CR 250 0.54 kg
Brunidor de camisa de cilindro (automóveis) Abertura : 70 a 150 mm

CR 250 A 0.04 kg
Jogo de pedras (2pc) e feltro (2pc) para brunidor CR 250 (grana-120)

CR 07 S 1.00 kg
Rosca M14

CR 07 AS Universal
Rosca M12

Suporte para Relógio Comparador

CR 233 0.02 kg
Ferramenta para travar volante do motor (regulável - uso universal)

CR 13 0.30 kg
Alicate para retirar os retentores das guias de válvulas.

CR 147 A 0.37 kg
Ferramenta para facilitar a colocação do retentor de válvulas a fim de não danificá-lo. válvulas de: 5 / 5,5 / 6 / 7 e 8 mm

(*Foto Ilustrativa)

(jogo c/ 22 pçs.)

CR 212 TOP 7.51 kg
conjunto de ferramentas (22 pçs) para comprimir molas de válvulas na montagem de cabeçote. (motores 3,4,6,5 e 8 cil.) acompanha suporte metálico para display e embalagem em caixa de madeira

CR 129 1.16 kg
Ferramenta para retenção das polias do comando de válvulas FORD / GM / FIAT / VW

CR 129 A 0.81 kg
Ferramenta para retenção das polias do comando de válvulas (USO UNIVERSAL)

CR 233 A-B 0.47 kg
Ferramenta para travar volante do motor (4 dentes) com inclinação.
CR 233-A para engrenagens com passo 6,35 mm
CR 233-B para engrenagens com passo 7,85 mm

**CR 240**

Suporte para remoção e recolocação do câmbio. (Este suporte é utilizado com auxílio de um macaco jacaré.) Aplicação: DUCATO / BOXER / JUMPER. **11,9 kg**

**CR 500 B**

Gancho completo (acessório p/ CR 500 A / B / C) **0,70 kg**

**CR 500 TOP**

Suporte para sustentação de motores Regulagens: alt. - larg. 2 ganchos/articulados Aplicações: Utilizado p/ sustentação e remoção / motor / câmbio - (alta resistência / versátil) **14,0 kg**

**CR 500 E**

Adaptador e acessórios para CR 500-A. Permite a utilização do suporte em locais de difícil acesso nos veículos com inclinação na parte frontal onde é colocado o suporte, e ainda um braço auxiliar com a finalidade de sustentar o suporte no painel frontal do veículo **2,20 kg**

**CR 504**

Bandeja (360 x 380mm) para apoiar, instalar e remover caixas de transmissão de automóveis e utilitários leves. (SISTEMA DE INCLINAÇÃO POR MOLEJO) OBS: Utilizar com auxílio de macaco jacaré. **13,0 kg**

**CR 500 TOP II**

Nova versão do suporte CR 500 TOP Apoio de braço frontal com regulagem de inclinação para apoio no painel frontal do veículo Abertura de 1000 a 1800mm **24,0 kg**

**CR 500 A PLUS**

Suporte para sustentação de motores, com 02 ganchos, com regulagem de largura e inclinação. **9,56 kg**

**CR 500 C**

Suporte para sustentação e remoção motor / câmbio HONFA FIT **15,9 kg**

CR 500 D

Suporte para apoio e sustentação do motor para remoção de câmbios e embreagens.

Pode ser fixado ao coxim, ou ao fixador do quadro (agregado) roscas M12 X 1,5 ou M12 X 1,75 e M14 X 1,5mm Elimina o uso de macacos e girafas. Fácil manuseio, super reforçado, uso universal para veículos que não permitem a utilização dos tradicionais suportes que sustentam o peso do motor pela parte superior (Ex: CR 500)



17,1 kg

Carroceria

Fácil Aplicação

Coxim**CR 501**

Cavelete Pequeno (p/ sustentação de veículos) 300/500mm - 2 Ton. **2,82 kg**

**CR 507**

Suporte para motores: 4 cilindros álcool ou gasolina. Capacidade 165 kg, com bandeja removível **36,5 kg**

CR 503
Cavelete grande para veículos pesados (utilitários) 500 a 700 mm 4 ton. **7,29 kg**

**CR 502**

Cavelete longo (2mts) com regulagens e apoio para motores, câmbio, suspensão e escapamentos (capacidade máx. 200 kg) **36,5 kg**

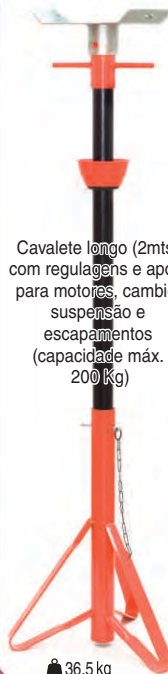
**CR 506**

35,0 kg

Macaco mecânico tipo sanfona (manual) para caixas de transmissão. Altura máxima: 1.880mm. Altura mínima: 1.170mm. Largura: 750mm. Capacidade: 200kgs. Bandeja: 380x250mm



CR 07
Suporte para relógio comparador FIAT: PALIO / MAREA / ALFA / BRAVA para verificação do PMS (rosca de 14 mm)
0,27 kg



CR 09
Ferramenta para regular a tensão da correia dentada do Tempra, Uno, Prêmio, Elba, Palio 8V, Tipo e Motor Fire 8V
0,15 kg



0,12 kg
Perfil Ribe
0,12 kg
CR 10
Chave tipo soquete longo (95mm) para aperto do cabeçote do Tempra, Tipo 2.0, Palio, Brava 1.6 16V (Ribe 11,60mm)



0,11 kg
Perfil Ribe
0,11 kg
CR 11
Chave tipo soquete longa (95mm) para aperto do cabeçote do Palio e Brava 1.6 16V e cabeçote superior do Palio Fire 16V (Ribe 8,85 mm)



0,13 kg
Perfil Ribe
0,13 kg
CR 11 A
Chave tipo "L" longa (200mm) para parafusos da árvore de manivelas e platô da embreagem: Marea 1.8 / 2.0 / Turbo, Brava HGT 1.8 (16V), Alfa Romeo 145 e 155 (Ribe 8,85 mm)



0,23 kg
0,23 kg
CR 15 A
Chave soquete longa (180mm) para os parafusos do cárter. Motor Powertrain FIAT e GM (Torx E10)



0,22 kg
0,22 kg
CR 18
Chave com imã especial para soltar os amortecedores traseiros do Tipo (compr. 155mm / sextavado de 15mm)



0,35 kg
0,35 kg
CR 18 A
Chave com imã especial p/ soltar a porca dos amortecedores traseiros: Elba, Palio Weekend, Adventure, Marea, Brava, Idea. (compr. 235mm / sextavado de 16mm)



0,83 kg
0,83 kg
CR 25 - Jogo
Ferramentas para troca da correia de distribuição e posicionamento do PMS Palio 1.0 e 1.5 (8V) (Também vendidas separadamente)

CR 25 A **CR 25 B** **CR 25 C**



0,44 kg
0,44 kg
CR 19
Ferramenta especial para tensionar o esticador da correia dentada do Palio, Brava, Siena, Doblo, Strada (1.6 16V) / Linea 1.9 16V



0,39 kg
0,39 kg
CR 26 TOP
Jogo c/ 2 ferramentas para posicionamento do PMS do 1º cilindro do motor Palio 1.6 16V, Brava, Siena, Doblo, Strada e Marea 1.6 16V Linea 1.9 16V



0,09 kg
0,09 kg
CR 32
Chave tipo "L" longa (200mm) p/ parafusos do motor de arranque, embreagem, fechadura da porta Palio e parafuso de fixação da polia de distribuição e carter Marea 1.8/2.0/Turbo/ Brava HGT, Alfa 145 / 147 / 155 / 156. (Ribe 6,80 mm)



0,11 kg
0,11 kg
CR 32 A
Chave tipo soquete para parafusos da fechadura da porta do Palio e embreagem (quando desmontada) e tampa de válvulas do Marea / Brava / Alfa - (Ribe 6,80 mm)



0,82 kg
0,82 kg
CR 38
Ferramenta p/ bloqueio da engrenagem de distribuição de admissão dos veículos: Palio, Palio Weekend, Siena, Strada, Doblo, Brava SX 1.6 16V e Linea 1.9 16V (usar c/ CR 38A para engrenagem de escape)



0,81 kg
0,81 kg
CR 38 A
Ferramenta para bloqueio da engrenagem de distribuição do veículo equipado com motor Fiat 1.0 / 1.5 - SPI e MPI 1.3 - Fire 1.8 / 2.0 turbo / Marea 1.8 / Brava HGT 1.6 16V e somente engrenagem dos veículos: Alfa 164 / 166/145 / 155 Ducatto / Boxer/jumper 2010... Iveco



0,20 kg
0,20 kg
CR 50
Chave 19 mm estriada, p/ sensor de temperatura de água do Tempra 16V com injeção eletrônica (compr. 110mm)



0,24 kg
0,24 kg
CR 50 A
Chave sextavada 21mm, para o sensor de óleo: Uno 1.3, 1.5 Mille, Tempra MPI 8v/SW, Tipo 1.6 IE 2.0 8v, Palio (todos), Marea 2.0, 2.4 e Turbo, Brava 1.6 16v, Doblo, Stillo, Alfa 155 e 145



0,18 kg
0,18 kg
CR 52
Chave tipo soquete longa (145mm) para aperto do cabeçote do Marea (todos), Alfa 145 / 147 / 155 / 156 Twin Spark e Brava HGT (Ribe 13,40 mm)



0,29 kg
0,29 kg
CR 53
Chave de garras para a porca do cartucho do amortecedor do Uno, Tempra, Palio (compr. 100mm)



0,30 kg
0,30 kg
CR 55
Ferramenta para bloquear o volante do motor nos veículos da linha FIAT 1.0, 1.3, 1.5 (uso local) e Alfa Romeo (uso em bancada)



0,13 kg
0,13 kg
CR 57
Ferramenta para travar volante do motor nos veículos: Marea 1.8 16V / 2.0 20V / Turbo 2.420V / Brava



0,35 kg
0,35 kg
CR 66
Jogo contendo 03 pçs para as porcas do amortecedor dianteiro do Corsa, Astra, Tipo, Marea, Fiesta 2002....
Obs.: Utilizar chave 6mm Allen (CR 59)



0,29 kg
0,29 kg
CR 67
Chave estriada para parafusos do cabeçote FIAT: Uno e Prêmio 1.300, Mille e Palio 1.0 e 1.5 (17 mm)



0,32 kg
0,32 kg
CR 67 A
Chave estriada para parafusos do cabeçote FIAT: Tipo e Uno com motor Argentino 1.6 (15mm)



0,36 kg
0,36 kg
CR 70
Chave estriada para porcas do distribuidor dos veículos: Prêmio, Uno 1.300 e Chevette (15 mm)



0,32 kg
0,32 kg
CR 78
Conjunto c/ 02 pçs sextavado (22 e 30mm) para porcas dos amortecedores traseiros e dianteiros do Tempra e Tipo.



1,19 kg
1,19 kg
CR 79
Chave tipo L compr. 350mm, sextavado externo de 19mm para porca do cubo traseiro do FIAT Tipo



0,33 kg
0,33 kg
CR 83
Jogo c/ 02 pçs de soquetes extra longos (250mm) especial para retirada do cárter e tampa de válvulas do FIAT Marea



1,77 kg
1,77 kg
CR 90
Chave L sextavada de 30mm para porca do cubo de roda dos veículos: UNO, e também nas linhas GM, FORD e VW (compr. 340mm). Dispensa uso de extensão



CR 91

Chave L sextavada de 32mm para porca do cubo da roda dianteira dos veículos: TIPO, PALIO, e também das rodas traseiras dos veículos Palio, Marea, Uno, Tempra e Stilo. E também nas linhas GM, FORD e VW. Dispensa uso de extensão. (compr. 340mm).  1.85 kg



CR 97

Chave para travar a polia da bomba d'água dos motores: FIAT e também VW e FORD  0.28 kg



CR 136 B

Ferramenta especial p/ travar comando de válvulas (uso no local) FIAT: Stilo, Idéa, Palio, Siena e Strada (1.8 8V) e GM: Kadet, Monza, Corsa, Omega, Vectra 2.0, Meriva 1.8 (compressão de molas c/ cabeçote ainda montado) ACOMPANHA ACESSÓRIO P/ SER UTILIZADO EM VHC FLEX POWER / ECONOFLEX. (136 A)  0.35 kg



CR 58

Ferramenta para posicionamento do PMS dos eixos dos comandos de válvulas do Marea 2.0 20V 142CV até Chassi 7012218  0.19 kg



CR 105

Ferramenta para posicionamento do PMS dos eixos de comando de válvulas: Marea SX e Brava HGT 1.8 16V  0.24 kg



CR 106

Ferramenta para posicionamento do PMS dos eixos de comando de válvulas: Alfa Romeo 145 e 155 Twin Spark 146, 147 e 156 (1.8 e 2.0 / 16V)  0.25 kg



CR 120

Ferramenta para posicionamento do PMS dos eixos de comando de válvulas do Marea Turbo 182CV (2.0 20V)  0.25 kg



CR 121

Ferramenta p/ posicionamento do PMS dos eixos do comando de válvulas do Marea 2.0 20V 127 cv. e 142 cv. do Chassi 7012218 em diante  0.25 kg



CR 122

Ferramenta p/ posicionamento do PMS dos eixos do comando de válvulas do Alfa 164 e 166 (3.0 V6 24V)  0.59 kg



CR 156

Ferramenta para posicionamento do PMS dos eixos de comando de válvula do Fiat Stilo: 2.4 20V 170CV  0.23 kg



CR 158

Ferramenta p/ posicionamento do PMS dos eixos de comando de válvula do Marea 2.4 20V/160CV  0.25 kg



CR 107

Ferramenta para tensionar correia rotante: Alfa Romeo 145 e 155 Twin Spark  0.12 kg



CR 108

Ferramenta para tensionar correia dentada: Marea SX e Brava HGT 1.8 16V  0.10 kg



CR 109

Ferramenta para travar eixos do comando de válvulas em PMS motor Fire 16V Palio, Palio Weekend, Strada, Siena 1.0 e 1.3  0.28 kg



CR 110

Ferramenta para tensionar correia de distribuição motor Fire: Palio, Palio Weekend, Strada, Siena 16V / Uno Evo / Fire 1.0, 1.3, 1.4 (8V) 1.0, 1.3 (16V) / EVO 1.0, 1.4 (8V) TJet 1.4, 1.6V, / Etorx 1.6, 1.8 (16V)  0.18 kg



CR 114

Extrator do terminal da barra de direção: FIAT - Palio, Marea, Tempra e também nas linhas: GM - Corsa FORD - Escort / VW - Fusca, Gol, Saveiro, Parati / Citroën C3  0.52 kg



CR 130

Ferramenta para travar o volante do motor Fire 16V (uso no local) 1.0, 1.3, 1.4, 8V 1.0, 1.3 16V  0.26 kg



CR 135

Jogo c/ 03 peças p/ soltar e apertar as porcas dos amortecedores dianteiros: Palio 1.0 e 1.5, Uno / Elba / Fiorino / Prêmio OBS.: (Usar com CR 59)  0.53 kg



CR 111

Calibre para posicionamento dos êmbolos (fasar) motor Fire 1.0, 1.3 16V, Doblo/ Palio / Siena  0.57 kg



CR 133

Ferramenta para travar comando de válvulas motor Fire 8V 1.0, 1.3, 1.4 Idea, Mile, Palio Punto, Siena e Strada  0.28 kg



CR 137

Chave tipo soquete longa (100mm) p/ os parafusos do cabeçote ao bloco: Fiat - Fire 1.0 / 1.3 - 8 e 16V (Ribe 9,85 mm)  0.11 kg



CR 142

Jogo contendo 07 pçs para retirar o rolamento da roda dianteira: Tempra/Tipo/Uno I - CR 142 A - para uso no Tempra, Tipo, Marea, Brava e Idea II - CR 142 B - para uso no Uno Usar com prensa hidráulica  4.60 kg



CR 144

Ferramenta para verificação do posicionamento do tensor compensador da correia dos órgãos auxiliares Marea 20V e Turbo  0.09 kg



CR 145

Ferramenta para remoção e recolocação do sensor de velocidade Marea 5 cil. (todos)  0.11 kg



CR 146

Ferramenta para aperto do braço oscilante Palio  0.10 kg



CR 151

Chave tipo canhão longa (300mm) c/ sextavado de 13mm para (des)montar o suporte da bateria Palio  0.38 kg



CR 170

Ferramenta especial com sextavado de 12 mm para soltar e apertar bujão de óleo do câmbio nos veículos: Marea (todos), Brava 1.8, Stilo 2.4 e Alfa 145 -147 - 155 - 156  0.23 kg



CR 154

Ferramenta p/ travar polia do virabrequim nos veículos: Stilo, Palio, Strada, Siena, Corsa e Meriva (1.8 / 8 e 16V) Motor Powertrain  1.22 kg



CR 153

Ferramenta especial p/ travar o volante do motor noveiculo (uso no local) GM: Meriva 8 e 16V / Corsa 1.8 8V - FIAT: Stilo 1.8 8 e 16V, Strada 1.8 8V, Siena 1.8 8V e Palio 1.8 8V (todos equipados com motor Powertrain)  0.36 kg



CR 155

Ferramenta para (des)montar conjunto bóia-bomba (combustível) Fiat Stilo, Doblo, Courier, Renault, Fiesta 2002, Eco Sport, Alfa Romeo 146 e 147 (porca ranhurada de 150mm)  0.51 kg



CR 159

Ferramenta p/ colocação dos tampões de água (selo) com 50mm de diâmetro, nos veículos: FIAT com motor Fire e Marea 20V  0.63 kg



CR 175

Ferramenta para soltar o sensor da bóia do tanque de combustível: Uno e Palio  0.18 kg



CR 195

Ferramenta para sacar e colocar as buchas da suspensão dianteira (família Palio) Obs.: Não deve ser utilizada na bandeja traseira do FIAT Strada.

0.91 kg



CR 195 A

A Fuso roscado (175mm) completo para substituição da ferramenta CR 195-A 132mm x M12 x 1,75 laminada

0.20 kg



CR 196

Ferramenta para sacar volante de direção: (Palio, Tempira, Uno)

0.45 kg



CR 197

Ferramenta para sacar e colocar bucha elástica da suspensão traseira família Palio- chassis: 8966 (Maio 1996...)

2.07 kg



CR 197 A

Fuso roscado (325mm) com porcas e arruelas para substituição CR 197 180mm x W5/8" x 11Fpp

0.49 kg



CR 203

Chave soquete longo de 36 mm X 3/4" para porca da homocinética: TEMPRA, MAREA e BRAVA. e também nos veículos: S10 / Blazer (4X4) e Citrën Picasso

0.48 kg



CR 204

Chave soquete longo de 38 mm X 3/4" para porca da polia do virabrequim UNO, FIORINO, ELBA e Prêmio

0.57 kg



CR 216

Ferramenta para sacar e instalar TPS e motor de passo nos veículos da linha FIAT: Uno, Palio, Brava e Fiorino, que tenham corpo de borboleta SNAP-IN

2.72 kg



CR 268

Soquete 52mm para coxim elástico superior do amortecedor traseiro do Uno e Premio

0.82 kg



CR 288

Ferramenta para sacar a pista do rolamento das rodas traseiras Fiat Uno / Strada até 2007

1.11 kg



CR 288 A

Ferramenta para sacar a pista do rolamento das rodas traseiras Fiat Uno / Strada 2007 em diante

1.16 kg



CR 265

Ferramenta para travar comando de válvulas do motor 1.0 e 1.4 8v EVO FIAT

0.23 kg



CR 266

Ferramenta usada na fasagem do motor, imobilizando a polia dentada, utilizando-se da marca de referência. Motor: FIAT EVO 1.0 / 1.4 8 VALVULAS

0.16 kg



CR 267

Ferramenta para guiar a tampa dianteira do motor 1.4 8v. - EVO FIAT

0.69 kg



CR 289

Chave estriada de 36mm c/ encaixe p/ cabo de 1/2" p/ filtro de óleo dos motores Fiat: E-Torq MWM NGD 3.0

0.12 kg



CR 269

Ferramenta para travar polia do virabrequim e polia do comando de válvulas, motor TRITEC / E.torQ

1.10 kg



CR 290

Ferramenta para tensionar correia dentada UNO FIRE 1.0 e 1.4

0.55 kg



CR 292

Chave Soquete estriado de 13mm longo encaixe de 1/2". Cabeçote dos motores FIRE 1.0 / 1.3 / 1.4 8v

0.26 kg



CR 322

Ferramenta para extrair A polia dentada da árvore de manivelas dos motores Fiat 1.6/1.8 16V E-torq aplicados no Palio, Doblo, Bravo, Siena, Idea, Linea, Strada e Punto

2.50 kg

CR 323

Ferramenta para instalar as polias dentada e da correia poly-v da árvore de manivelas dos motores Fiat 1.6/1.8 16V E-torq aplicados no Palio, Bravo, Doblo, Siena, Idea, Linea, Strada e Punto.

1.14 kg



CR 386

Chave soquete 13mm para o sensor de temperatura linha Fiat 2017.... / Argo

0.12 kg



CR 414

Ferramenta para remoção da correia dos órgãos auxiliares (alternador/ar condicionado/bomba de direção) FIAT E-TORQ 1.6/1.8 16v. 2011... (meds 1/2" x 1/2")

0.24 kg



CR 418

Extrator da polia do virabrequim FIAT / Jeep Motor E-TORQ

1.93 kg



CR 473

Jogo de 2 ferramentas para sincronismo do motor E-TORQ-EVO 1.8 Flex 2016... Toro e Renegade

1.75 kg

Consulte Seção Kit para Sincronismo



CR 342 - KIT FIRE

1.88 kg



CR 343 KIT EVO I

0.90 kg



CR 343 A KIT EVO II

0.95 kg

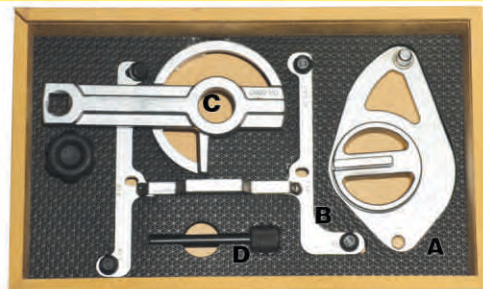

CR 365

Kit de ferramentas para sincronismo do motor FIAT FIRE FLY 3cc 1.0 e 4 cc 1.3 UNO e MOBY

1.96 kg

CR 365 A - Ferramenta de travamento da árvore de manivelas (volante do motor). Fiat Fire Fly 3cc 1.0 e 4 cc 1.3

CR 365 B - Ferramenta de travamento do comando de válvulas. Fiat Fire Fly 3cc 1.0 e 4 cc 1.3 3 cil - Aplicar a ferramenta no 1º mancal. 4 cil - Aplicar a ferramenta no 2º mancal.

Ambos os motores, a ferramenta é aplicada do mesmo lado, mudando apenas a fixação

CR 365-C - Ferramenta para imobilizar a polia da árvore de manivelas, afim de torquar o parafuso de fixação. Fiat Fire Fly 3cc 1.0 e 4 cc 1.3.

CR 365-D - Pino guia (70 x8,5mm) para alinhamento da polia junto a face da tampa da distribuição, (aplicado somente no modelo 1.0 3 cil - Polia com massa para contrabalançar o motor).

**CR 04**

Chave longa (370mm) para amortecedores dianteiros nos veículos: Passat, Gol, Voyage, Parati, Santana, Quantum.
(Porca do cartucho)  0.84 kg

**CR 17**

Chave tipo soquete longa (90mm) com boca cônica de 13,5mm para aperto da porca da biela dos motores CHT/AE, veículos: VW, e também nos veículos: Escort, Corcel, Del Rey, Belina, Ka e Fiesta até 99 e Monza

**CR 27**

Chave tipo soquete longa (135mm) multi-flutada de 12mm p/ cabeçote: Gol, Santana, Kombi Diesel, Golf 1.6 e 2.0 (07/2001...), Passat 1.8 e 2.0 até 97 e para soltar amortecedor dianteiro do Omega.

**CR 35**

Chave tipo soquete extra longa para: Parafusos do alternador VW: e também nas linhas: Ford e GM (TORX E8)  0.16 kg

**CR 36**

Chave para a porca espaçadora dos amortecedores Gol, Saveiro, Parati, Voyage. OBS: Não usar c/ máquina pneumática.  0.05 kg

**CR 37**

Colocar e sacar do rolamento da ponta do "Eixo Piloto" VW: linha refrigerado a água  0.10 kg

**CR 47**

Chave especial (compr. 70 mm) p/ porca amortecedor dianteiro linha VW, Golf de 95 em diante, Gol/Santana/ Quantum (usar c/ CR 54)  0.18 kg

**CR 47-A**

Chave especial p/ porca amortecedor dianteiro linha VW, Golf de 95 em diante, Gol/Santana/ Quantum (usar c/ CR 54)  0.34 kg

**CR 61**

Ferramenta para o travamento da polia do motor VW AT 1000 - 16V Gol e Parati. Com Regulação horizontal, para ser utilizado também no Vw Up. (a partir de 09.2019)  0.84 kg

**CR 61-A**

Ferramenta para o travamento da polia do virabrequim VW motor Power AZP - EA111 (II) 16V, Polo 1.0 (8 V e 16V)  1.02 kg

**CR 62**

Ferramenta para regular a tensão da correia dentada motores: VW AP 1.6, 1.8 e 2.0 8V e EA 111 / 113  0.17 kg

**CR 64**

Jogo de chaves (02 pçs), para soltar a porca do amortecedor traseiro do Santana e Quantum  0.29 kg

**CR 65**

Jogo de chaves (02 pçs) p/ soltar a porca superior do amortecedor traseiro do Logus, Pointer, Gol, Golf (95 em diante) e Mondeo  0.19 kg

**CR 76**

Chave soquete longa (140mm) Allen com sextavado de 10mm para parafusos do cabeçote, VW Passat  0.16 kg

**CR 81**

Ferramenta para movimentar, fixar e comprimir a mola do alternador para substituição da correia, VW motor AT.  0.20 kg

**CR 85**

Chave soquete estriado interno de 9mm para parafusos do platô VW AT.  0.11 kg

**CR 90**

Chave L sextavada de 30 mm para porca do cubo de roda dos veículos: vw e também nas linhas FORD, GM e FIAT (compr. 340mm). Dispensa uso de extensão  1.77 kg

**CR 91**

Chave L sextavada de 32 mm para porca do cubo de roda dos veículos: vw e também nas linhas FORD, GM e FIAT (compr. 340mm). Dispensa uso de extensão  1.85 kg

**CR 97**

Chave para travar a polia da bomba d'água dos motores: VW 1.6, 1.8, 2.0 e também nas linhas: FORD (AP) e FIAT  0.28 kg

**CR 113**

Extrator do terminal da direção VW: Santana, Quantum, Gol e Parati 95 em diante, e também nos veículos: Monza e Mitsubishi - L200  0.82 kg

**CR 114**

Extrator do terminal da barra de direção: VW: Fusca, Gol, Saveiro, Parati e Voyage e também nas linhas: FORD, FIAT e GM  0.52 kg

**CR 115**

Chave tipo soquete longa (135mm) para aperto dos parafusos do cabeçote dos veículos: Passat, Golf 2.0 (Alemão) e Audi A3 e A4 (1.6 e 1.8) **Obs: medida e perfil especial (10,30mm) diferente de Torx T55 (11,30mm), não recomendada para este fim**  0.15 kg

**CR 116**

Dispositivo especial para imobilização em PMS das engrenagens dos comandos de válvulas: VW AT 1.0, Gol, Parati/Turbo  0.19 kg

**CR 116-A**

Ferramenta especial p/ imobilização em PMS das engrenagens dos comandos de válvulas VW motor Power AZP EA 111 (II) 16V Gol e Parati Power (com 76cv) e Fox  0.13 kg

**CR 134**

Ferramenta para colocar e retirar a bucha da suspensão traseira: Linha VW Gol, Voyage, Parati e Saveiro até G4  1.23 kg

**CR 134 A**

Fuso roscado (213mm) para reposição da ferramenta CR 134 140mm M12x1,75  0.26 kg

**CR 138 A**

Extrator do terminal do Braço Pitman da direção da Kombi/Mitsubishi L200 e usado também na linha Mercedes Benz (utilitários)  1.17 kg

**CR 141**

Sacador e colocador do rolamento do cubo da roda dianteira GM (Monza, Kadett, Vectra 95/96, Corsa - VW, Gol 95...)  3.10 kg



FRENTE

CR 149 A

Ferramenta para colocar e posicionar o disco de sinal do sensor hall de rotação (roda fônica) Aplicação: VW-Motor Power EA 111 Gol 1.0 8 e 16v, Parati 1.0 turbo, Golf 1.6 Fox e Polo 1.6 (8 e 16v) VW Motor Power EA 113 Audi 1.8 turbo, Golf 1.8 turbo, Polo e Fox 1.0 (8V e 16V), 1.6 e 1.8 e Kombi 1.4 e Amarok  1.57 kg



VERSO

Observe-se que existem no mercado 02 tipos de disco, (Roda Fônica):
1) fabricante CORTECO/FREUDENBERG (VW) - Este disco é metálico com dentes tipo engrenagem.
2) Fabricante SABO - Este disco é do tipo Roda Fônica magnética, por onde os sinais são emitidos. Consulte o explicativo que acompanha a ferramenta

**CR 152**

Chave para a Porca do Amortecedor dianteiro: Golf 99 em diante, Audi / Bora, Renault Clio, Mégane e Scénic e Peugeot 206 e 307 Citroën C3 (Usar com CR 54)  0.14 kg

**CR 160**

Chave "L" multidentada de 16mm c/ guia de segurança p/ câmbio Golf e Polo / Passat e Audi A3  0.32 kg

CR 160 A
 Chave com ponta multidentada de 16 mm (com guia de segurança) Sextavado para encaixe de 13 mm comprimento total 40mm (ideal para bujão de óleo - câmbio/motor) em lugares de difícil acesso dos veículos da linha vw: Audi/ Passat/ Golf/ Polo/ Fox
 0.04 kg

CR 167
 Extrator do rolamento da 5ª marcha: Santana, Quantum, Gol, Parati, Voyage e Saveiro
 1.24 kg

CR 177
 Ferramenta para posicionar as polias de comando de válvulas em PMS.Audi: 2.4 / 2.7 / 2.8 - 12 e 30 V e Passat 30V
 VW Import
 2.29 kg

CR 177 A
 Ferramenta para travar virabrequim: Audi: 2.6 / 2.8 - 12V 2.4 / 2.7 / 2.8 / 3.0 e Passat 30V
 VW Import
 0.10 kg

CR 217
 Ferramenta para (des)montar o conjunto bóia-combustível do Gol e Kombi 95 a 2005 que possuem trava metálica no conjunto (2 1/2)
 0.51 kg

CR 221 A
 Ferramenta para Colocar e sacar as duas buchas da suspensão dianteira: Fox e Polo
 3.30 kg

CR 221 B
 Fuso roscado para reposição da ferramenta CR221-A
 0.22 kg

CR 223
 Chave L com guia de segurança perfil especial (five lobby) para os parafusos do sensor de fluxo de ar (MAS) dos veículos: Gol Turbo, Golf, Audi, Bora e New Beattle
 0.01 kg

CR 234
 Ferramenta para "abrir" a manga de eixo da suspensão dianteira, a fim de soltar os amortecedores nos veículos: VW: Polo, Golf e Audi e também nos veículos: Ford: Fiesta 2002... e Escort 97
 0.12 kg

CR 252
 Ferramenta especial para luva ranhura de 15 dentes da transmissão automática: Passat, Audi, Golf e Variant
 0.62 kg

CR 253
 Compressor de molas da suspensão traseira: VW Gol, Voyage, Parati e Saveiro
 1.11 kg

CR 255
 Jogo de guias para introdução do retentor do eixo de comando de válvulas: motor AP 1.6 / 1.8 / 2.0
 0.34 kg

CR 256
 Ferramenta para introduzir e retirar a bucha do pino central da suspensão dianteira da Kombi
 1.10 kg

CR 258
 Ferramenta para sacar e introduzir (no local) as buchas da bandeja da suspensão dianteira: VW Gol, Voyage, Saveiro, Parati, Quantum e Santana (até Out. 86)
 1.56 kg

CR 258 A
 Fuso roscado (263mm) para reposição da ferramenta CR 258 1,66mm x W5/8" x 11Fpp
 0.42 kg

CR 259
 Ferramenta para sacar e introduzir as buchas da suspensão dianteira do Bora, Audi A3, Golf e Polo (Classic)
 2.71 kg

CR 259 A
 Fuso roscado (235mm) para reposição da ferramenta CR 259 155mm x M12 x 1,75
 0.27 kg

CR 261
 Chave "L" (Especial) Multidentada (12mm) para os Parafusos do Coxim da Kombi (Refrigerada - Água)
 0.24 kg

CR 282
 Dispositivo para extração com auxílio de prensa do conjunto De rolamentos SKF BB1 3155 0304041D acoplados à placa VW 02T 311206 e, que compõe a transmissão (mecânica) dos veículos VW: Fox, Saveiro, Gol, Voyage, Polo (Geração V) e Audi A3, Passat, Jetta
 6.55 kg

CR 304
 Chave soquete estriado de 30 mm com encaixe quadrado de 3/4" para a porca do eixo dianteiro. (HOMOCINÉTICA) VW: GOLF, BORA, AUDI A3
 0.42 kg

CR 305
 Chave soquete estriado de 36mm com encaixe quadrado de 3/4" para a porca do cubo dianteiro (HOMOCINÉTICA) .VW : POLO, FOX e CROSSFOX
 0.47 kg

CR 307
 Ferramenta especial (12 dentes) encaixe quadr. 3/4" para luva ranhurada da transmissão (pré carga) automática Passat, Audi, Golf (Motorização transversal)
 0.56 kg

CR 308
 Ferramenta para colocar e retirar as buchas do quadro da suspensão traseira./POLO/ AUDI A3 / NEW BEETLE/ FOX/GOLF 99...
 2.61 kg

CR 321
 Ferramenta especial longa com encaixe estriado de 14 e 15mm para levantar o tensor da correia dentada: Linha VW
 0.34 kg

CR 310 A
 Conjunto de extratores para sacar o cubo e rolamento da suspensão dianteira (COM TRAVA) GOLF/JETTA/AUDI (uso no local) Utilizar em conjunto com CR 310
 2.74 kg

KIT COMPLETO Linha VW e GM
CR 179 / Jogo
 Extrator e instalador da bucha de bandeja VW: Gol, Parati, Saveiro, Santana, Quantum e também na linha GM: Obs.: acompanha 5 tipos de porta bucha
 5.52 kg

VW 01
 GM 02
 GM 03
 GM 01
 VW 02

Copos saca bucha (fabricados em material fundido de alta resistência) poderão ser vendidos separadamente.
 Cód.: CR 179 / VW 01 / VW 02 / GM 01 / GM 02 / GM 03

CR 310
 Ferramenta para sacar o cubo e rolamento da suspensão dianteira. POLO, FOX, GOLF
 5.72 kg



CR 336 A

Ferramenta para imobilização da árvore de comando das válvulas VW motor EA 211 que equipam os veículos: Up / Fox (12 V) / Gol MSI 16 V G6 2015
 ⚖️ 0.25 kg



CR 336 B

Pino posicionador e bloqueador da árvore de manivelas VW motor EA 211 veículos: Up / Up TSI / Fox / Gol 16 V / MSI G6 e Golf 1.4 TSI 2015
 ⚖️ 0.08 kg



CR 336 C

Ferramenta para imobilizar as polias trioval de comando de válvulas VW motor EA 211 que equipam os veículos: Up / Up TSI / Fox (12V)
 ⚖️ 0.09 kg



CR 336 KIT (6 pcs)

Jogo de ferramentas para sincronismo dos motores VW EA 211. Up / Up TSI / Fox e Gol MSI G6-12 e 16V / Golf 1.4 TSI
 composição das ferramentas: CR 336-A / B / C / D / E / F
 ⚖️ 3.20 kg



CR 336 D

Ferramenta para imobilização da árvore de comando das válvulas motor EA 211 VW TSI Up / Golf 1.4
 ⚖️ 0.28 kg



CR 336 E

Ferramenta boca dodecagonal 30mm para soltar a polia tensora VW motor EA 211 veículos: Up / Up TSI / Fox Gol 16V MSI e Golf 1.4 TSI
 ⚖️ 0.16 kg



CR 336 F

Ferramenta para imobilizar a polia da árvore de manivelas (com amortecedor de vibrações) veículos: Up / Up TSI / Fox Gol 16V MSI e Golf 1.4 TSI
 ⚖️ 1.30 kg



CR 336 Jogo (5 pcs)

Jogo de ferramentas (5 Peças) para sincronismo dos motores EA 211:UP/UP TSI/FOX 12Ve GOL MSI 1.6 16V e GOLF 1.4 TSI (CR-336-A/B/C/D/E)
 ⚖️ 1.45 kg



CR 71 B M10

⚖️ 0.21 kg

Chave tipo soquete Extra longa (180mm) multidentada de 10mm para: - Cabeçote AUDI Parafusos da válvula EGR.AMAROK



CR 331

Ferramenta para travar e girar o amortecedor de vibrações. Polia do virabrequim VW TSI: Jetta / Passat / Tiguan / Golf
 ⚖️ 1.03 kg



CR 332

Conjunto de ferramentas tipo soquete com encaixe de 1/2" para as válvulas dos variadores de fase dos motores EA 888 1.6 e 2.0 16V TSI/TFSI. 1-06H109257-A (nº da peça original) 2-06H109257-B (nº da peça original) 3-06H109257-C (nº da peça original)
 ⚖️ 0.81 kg



CR 334

Ferramenta para sacar bico injetor (2 adaptadores - 11 e 14mm) AUDI / JETTA / GOLF / PASSAT e outros veículos com bico injetor dentro dessas medidas
 ⚖️ 1.30 kg



CR 338

Ferramenta de imobilização do cubo da engrenagem dos eixos dos comandos. VW Amarok 2.0 turbo
 ⚖️ 0.55 kg



CR 339

Extrator do cubo da engrenagem do eixo de comando de válvulas VW Amarok 2.0 turbo
 ⚖️ 0.61 kg



CR 449

Ferramentas para soltar a válvula termostática. FOX/GOL/POLO/ UP/SAVEIRO/VIRTUS/GOLF
 ⚖️ 0.08 kg



CR 371

Jogo de ferramentas para travar as engrenagens dos comandos de válvulas dos motores EA 888 1.6 2.0 16V TSI/TFSI.
 ⚖️ 0.35 kg



CR 380

Chave especial em perfil "L" Multidentada de 12mm com encaixe de 1/2" para os parafusos que sustentam o cambio DSG dos veículos VW TSI
 ⚖️ 0.15 kg



CR 388

Ferramenta para comprimir o Tensionador das correntes dos comandos de válvulas Audi /Passat FSI e Audi: 1.8-20v/2.7, 2.8-20v/ 4.2-40v
 ⚖️ 0.03 kg



CR 389

Ferramenta especial para configurar e ajustar o eixo dos comandos de válvulas (variável) dos motores VW TSI EA 888 geração III (2015...) Afim de posicionar a ferramenta CR 371/1
 ⚖️ 0.12 kg



CR 407

Ferramenta para sacar o bujão do óleo do cárter de plástico Audi; A1, A3, A4, A5, A6, A7, Q3, Q5, Q7, TT, TTS VW; Beetle, Golf, Jetta, Passat, Polo, Tiguan,
 ⚖️ 0.23 kg



CR 340

Ferramenta para sacar bobina de ignição (uso universal - linha VW eletrônico)
 ⚖️ 0.17 kg



CR 340 A

Ferramenta para sacar o conector (4 Pinos) da bobina de ignição. Audi/Jetta/Golf/VW TSI/TFSI
 ⚖️ 0.16 kg



CR 340 B

Ferramenta para sacar o conector metálico do cabo de ignição
 ⚖️ 0.16 kg



CR 348

Ferramenta para remover e instalar o módulo do eixo de equilíbrio da árvore intermediária. AMAROK
 ⚖️ 0.06 kg



CR 18001

Chave para soltar a sonda do sensor de temperatura da AMAROK 17mm
 ⚖️ 0.09 kg



CR 474

Ferramenta para sincronismo e posicionamento entre as engrenagens dos comandos de válvulas VW 2.0 TDI Amarok (Utilizar com CR 319)
 ⚖️ 1.85 kg

 **CR 08**
Chave tipo soquete longa (95mm) para aperto dos parafusos da biela (motor Zetec) Torx e10
🔑 0.12 kg

 **CR 17** 🔑 0.19 kg
Chave tipo soquete longa (90mm) c/ boca cônica de 13,5mm p/ aperto dos parafusos da biela dos motores CHT/AE, veículos: Escort, Corcel, Del Rey, Belina, Ka e Fiesta até 99. e também nos veículos: VW e Monza

 **CR 20**
Chave soquete longa (135mm) p/ aperto dos parafusos do cabeçote motor ford zetec 16v (torx t55) 🔑 0.15 kg

 **CR 20 A**
Chave soquete longa (145mm) p/ aperto dos parafusos inferiores do cabeçote motor Zetec (Torx T40) 🔑 0.14 kg

CR 166
Extrator do rolamento (90mm) do câmbio F1000, F4000 e também eixos primários e secundários da D10 e D20
🔑 1.50 kg

 **CR 22**
Torx T55
Chave soquete para soltar e apertar parafuso central da polia do comando de válvulas motor Zetec. 🔑 0.09 kg

 **CR 33** 🔑 0.51 kg
Jogo com 02 pinos/rosca/limitadores e régua para afinação do PMSs dos motores Ford Zetec 1.4 e 2.0 16v Escort, Fiesta, Courier, Mondeo e Focus

 **CR 35**
Chave tipo soquete extra longa: para parafusos do alternador FORD: Escort, Ka. e também nos veículos GM / VW (Torx E8) 🔑 0.16 kg

 **CR 39**
Chave especial para o travamento das polias de comando de válvulas do motor Zetec. 🔑 0.94 kg

 **CR 68**
Chave tipo soquete (pentagonal) para (des) montar as pinças de freio do Escort, F4000, Belina, Del Rey 1.8 e Monza 🔑 0.07 kg

 **CR 47-A**
Chave tipo cachimbo, 22mm, para porca dos amortecedores dianteiros dos veículos FORD: Versalles/Escort (usar com CR 54 ou 59) 🔑 0.04 kg

 **CR 56** 🔑 0.09 kg
Chave tipo soquete para parafuso do pivô FORD: Escort e Verona (Torx T45)

 **CR 66**
Jogo contendo 03 pçs para as porcas do amortecedor dianteiro do Corsa, Astra, Tipo, Marea, Fiesta 2002... e Ecosport obs.: utilizar chave 6mm allen (CR 59)
13mm 21mm 19mm 8x10mm 10mm 🔑 0.35 kg

 **CR 114**
Extrator do terminal da barra de direção: Ford e também nas linhas: VW, FIAT e GM, CITROËN C3 🔑 0.52 kg

 **CR 86**
Ferramenta especial para travar a polia da árvore dos motores Maxion International HS 2.5 e 2.8 🔑 1.90 kg

 **CR 87** 🔑 0.43 kg
Chave especial (32mm) p/ retenção do retenção do eixo do ventilador do motor Maxion International HS 2.5

 **CR 87 A** 🔑 0.43 kg
Chave especial (36mm) p/ retenção do eixo do ventilador do motor Maxion International HS 2.8

 **CR 90** 🔑 1.77 kg
Chave I sextavada de 30 mm para porca do cubo de roda dos veículos: Frd: Escort, e também nas linhas GM, Fiat e VW (compr. 340mm). dispensa uso de extensão

 **CR 91** 🔑 1.85 kg
Chave L sextavada de 32 mm para porca do cubo da roda dos veículos: FORD: Escort e Verona, e também nas linhas GM, FIAT e VW. dispensa uso de extensão. (compr. 340mm).

 **CR 97** 🔑 0.28 kg
Chave para travar a polia da bomba d'água dos motores 1.6, 1.8, 2.0 ford e também nas linhas FIAT e VW

 **CR 117** 🔑 0.12 kg
Ferramenta para regulagem do sincronismo do volante (PMS) nos motores Maxion International HS 2.5 / 2.8 e NGD 3.0 e MS 4.1

 **CR 118** 🔑 0.06 kg
Ferramenta para fixação da engrenagem da bomba injetora. (pino-trava) motor Maxion International 2.5 e 2.8

 **CR 124** 🔑 0.14 kg
Chave tipo soquete longa (90mm) para soltar o parafuso do câmbio: ford 1.6/1.8 (Torx T60)

 **CR 127 A**
Extrator de pivôs Ranger e F1000 e também pivô inferior da S10 / Blazer 🔑 2.91 kg

 **CR 155**
Ferramenta para (des)montar conjunto bóia-bomba (combustível) Courier, Fiesta 2002, Eco Sport, (porca ranhurada de 150mm) 🔑 0.51 kg

 **CR 183** 🔑 0.48 kg
ferramenta para sacar a polia do virabrequim dos motores maxion internacional hs 2.5 e 2.8

 **CR 223** 🔑 0.01 kg
chave I com guia de segurança perfil especial (five lobby) para os parafusos do sensor de fluxo de ar (mas)

 **CR 224** 🔑 0.09 kg
ferramenta para travar comando de válvulas do motor maxion ngd 3.0 (eletrônico) ranger 2006 ...

 **CR 234** 🔑 0.12 kg
Ferramenta para "abrir" a manga de eixo da suspensão dianteira, a fim de soltar os amortecedores nos veículos FORD: Fiesta 2002... e Escort 97... e também nos veículos VW: Polo, Golf e Audi

 **CR 283** 🔑 0.98 kg
Extrator da engrenagem da 5ª marcha, dos veículos FORD equipados com motores: cht (1.6) Rocan (1.0 / 1.6 8v) e Zetec (1.4 / 1.6 8v)

 **CR 309** 🔑 1.00 kg
Ferramenta para instalar e sacar a bucha menor (de borracha) da bandeja da suspensão dianteira. FORD Fiesta 01... Ecosport

 **CR 309 A** 🔑 0.31 kg
Fuso roscado (230mm) para reposição da ferramenta CR 309 230mm x M12 x 1,75

 **CR 324**
Conjunto de ferramentas para sincronismo: Ford Fusion e Focus 2.0-L ECO BOOST 2013... Ranger Rover Evoque 2.0 Si 4 2011 a 2014 🔑 0.61 kg

 **CR 326**
Jogo de ferramentas para sincronismo motor Ford Duratec 1.6-1 16V VTI (120cv) geração Sigma com comando de válvulas variável. veículos: New Fiesta/Focus/ Ecosport 2014... 🔑 1.25 kg

 **CR 326-A**
Jogo de ferramentas para travamento dos eixos de comando de válvulas e bloqueio do virabrequim. Ford 16V.2.0/2.3/2.5 Duratec 1.5/1.6 Sigma / Volvo C-30 2.0 motor B4204S3 🔑 0.29 kg

 **CR 326 B**
Dispositivo para posicionar em sincronismo as polias dos comandos de válvulas com variador de fase. FORD: Motor Sigma. VOLVO: MOTOR B4162 e B4164 🔑 0.46 kg



CR 327
Pino trava para virabrequim dos motores Ford 303 1.0-L Duratec (85 cv)
FORD Ka 2015...
obs: para travar o volante do motor utilize CR 233 ou CR 233-A

0.07 kg



CR 327 A
Jogo de ferramentas para sincronismo motor Ford 303 3 cil (85cv) Duratec FORD KA

0.46 kg



CR 328
Ferramenta para travar a polia do virabrequim.
Ford 1.4 16V (Fiesta e Courier) utilizar: dois parafusos: (M8x1,25) e CR 129

0.44 kg



CR 353
Jogo (2pçs) sextavado vazado de 13mm e L em perfil para porca do amortecedor traseiro: FORD. KÁ e FIESTA 2014....

0.16 kg



CR 347
Jogo de ferramentas: para remover e instalar o sistema de dupla embreagem nos câmbios Dps6 POWER SHIFT
Obs: Somente para instalar o conjunto novo, esta ferramenta não faz o reset do conjunto retirado

10.5 kg



CR 347 A
Jogo de ferramentas para RESETAR o sistema de dupla embreagem DPS6 POWER SHIFT

5.13 kg



CR 369
Jogo de ferramentas para sincronismo motor DURATORQ TURBO DIESEL-CI: Ford Ranger 2.2.2.4 (4cc) e 3.2 (5cc) / Transit 2.2.2.4 (4cc)/ Troller T4 3.2 (5 cc). e Land Rover Defender 2.4

1.28 kg



CR 392
Jogo de dispositivos para imobilizar os comandos de válvulas em PMS dos motores Ford EDGE 3.5 24v DURATEC 2009...

1.99 kg



CR 416
Jogo de ferramentas para bloquear e sacar a tampa, o retentor e o carreto da bomba (de alta) de combustível nos motores a diesel 2.2/3.2 Ford Duratorq TDCI durante a remoção e instalação de forma a não interferir com a corrente de distribuição e o sincronismo do motor.

1.23 kg



CR 451
Chave tipo soquete longa (120mm) Perfil Ribe 13,20mm para aperto do cabeçote dos motores FORD DRAGON 1.5L 3CIL

0.14 kg



CR 453
Ferramenta para posicionamento dos comandos de válvulas dos motores: FORD DRAGON 1.5L 3CIL

0.58 kg



CR 454
Ferramenta para bloqueio do volante do motor: FORD DRAGON 1.5L 3CIL

0.31 kg



CR 455
Ferramenta de alinhamento do eixo balanceador: FORD DRAGON 1.5L 3CIL

0.17 kg



CR 456
Instalador do vedador da vela de ignição: FORD DRAGON 1.5L 3CIL (utilizar com auxílio do cabo CR 26002- que não acompanha a ferramenta)

0.13 kg



CR 457
Extrator da polia do virabrequim FORD DRAGON 1.5L 3CIL

1.44 kg



CR 458
Instalador do tubo de vedação (vedante dianteiro do virabrequim) FORD DRAGON 1.5L 3CIL

0.59 kg



CR 459
Ferramenta para travar a engrenagem (TESOURA) do motor: FORD DRAGON 1.5L 3CIL

0.05 kg



CR 461
Medidor de pressão de óleo do motor: FORD DRAGON 1.5L 3 CIL do sistema de pressão variável controlada por modulo (pressão modulada)

1.36 kg



CR 471
Chave tipo soquete longa (180mm) perfil especial (10,30mm) para aperto dos parafusos do cabeçote dos motores Ford Zetec Rocam 1.0 3 cil. e 16 e 8 V

0.14 kg



CR 03

Chave de 46 mm para ajuste da tensão da correia dentada do motor do Monza e Kadett

0.41 kg



CR 14

Chave tipo soquete longa (95 mm) p/ aperto dos parafusos do cabeçote do Corsa e também p/ os amortecedores do Mercedes Classe A, Citroën e Peugeot (TORX E12)

0.12 kg



CR 15

Chave "T" longa (200 mm) com cabo para os parafusos de fixação do cârter do Corsa / Zafira / Montana / Celta / Vectra (TORX E10)

0.16 kg



CR 15-A

Chave soquete longa (180 mm) para os parafusos do cârter Motor Powertrain GM e FIAT (TORX E10)

0.23 kg



CR 16

Chave "L" (compr. 140 mm) para parafusos dos protetores da polia do motor dos veículos: GM (TORX E10)

0.11 kg



CR 24

Chave tipo soquete longa (100 mm) p/ aperto dos parafusos do cabeçote do Omega, Astra 1.8, S10 2.2, Vectra e também nos veículos: Peugeot 405, Citroën, Zetec Rocan (Fiesta e Ka) (TORX T55)

0.13 kg



CR 34

Chave especial para parafusos da flange do cardan do Omega (TORX E12)

0.17 kg



CR 35

Chave tipo soquete extra longa para: Parafusos do alternador GM e também para as linhas FORD e VW (TORX E8)

0.16 kg



CR 41

Chave tipo soquete longa (100 mm) para parafusos do alternador Omega, Kadett, Vectra. (TORX E8)

0.18 kg



CR 42

Chave tipo soquete longa (100 mm) p/ Corsa: regular a cambagem, manga de eixo traseiro. Corsa 16V engrenagem do comando de válvulas. Cabeçote Peugeot 206 1.6 16V (TORX E14)

0.30 kg



CR 41-T

Chave "T" longa (200 mm) usada no alternador (parte inferior) dos veículos: Omega/Kadett/Vectra: parafuso inferior do cârter Vectra, regulagem dos faróis S10; parafuso do sensor de velocidade do eixo comanda da válvula termostática do Corsa 16V. (TORX E8)

0.18 kg



CR 42-T

Chave tipo "T" longa (300 mm) com cabo deslizante para serviços diversos da linha GM (TORX E14)

0.40 kg



CR 45

Extrator do eixo piloto da embreagem e trava do platô dos veículos: Monza e Kadett até 92.

0.33 kg



CR 46-A

Pino avulso da ferramenta CR 46.

0.02 kg



CR 46

Removedor, instalador da luva da dobradiça da porta: Opala, Caravan, Kadett, Monza, Omega e Vectra

1.14 kg



CR 48

Chave tipo cachimbo para remoção da cebolinha do óleo: Omega, Monza, S10, Kadett, Blazer equipados com EFI / MPFI (compr. 200mm)

0.19 kg



CR 49

Chave tipo "cachimbo" (compr. 120mm) para soltar parafusos do distribuidor Omega (4cc). (TORX E8)

0.04 kg



CR 56

Chave tipo soquete p/ bujão do óleo e do cârter dos veículos GM: Vectra, Corsa e Astra. (TORX T45)

0.09 kg



CR 63

Ferramenta para regular a tensão da correia dentada da direção hidráulica do Monza e Kadett (91 em diante)

0.20 kg



CR 66

Jogo de chaves para as porcas do amortecedor dianteiro do Corsa, Astra, também nos veículos Tipo, Marea, Fiesta 2002..., Eco Sport (OBS: Utilizar chave 6mm Allen CR 59)

0.35 kg



CR 69

Jogo de chaves 19 mm para a porca do amortecedor dianteiro do Monza de 91..., Kadett e Vectra.

0.36 kg



CR 86

Ferramenta especial para travar a polia da árvore dos motores Maxion HS 2.5 e 2.8 dos veículos S10, Blazer, e também nos veículos: MB Sprinter, Ranger, Land Rover e F1000 ano 97

1.90 kg



CR 87

Chave especial (32 mm) para retenção do eixo do ventilador do motor Maxion HS 2.5

0.43 kg



CR 87 A

Chave especial (36mm) p/ retenção do eixo do ventilador do motor Maxion HS 2.8

0.43 kg



CR 90

Chave "L" sextavada de 30 mm p/ porca do cubo da roda dos veículos: Monza, Kadett, Astra, Zafira, Opala, e também nos veículos: Uno, Gol e Escort (compr. 340 mm). Dispensa uso de extensão.

1.77 kg



CR 95

Dispositivo especial p/ imobilização das engrenagens dos comandos de válvulas: GM - Astra 16V, Vectra 2.0, 2.2 e 2.4, Zafira 16V

0.19 kg



CR 96

Dispositivo especial p/ imobilização das engrenagens dos comandos de válvulas: GM - Corsa 16V 1.0 e 1.6/GSI, Meriva 1.8 e FIAT - Stilo 1.8

0.07 kg



CR 102

Chave para torquar a barra de direção na cremalheira do Corsa.

0.20 kg



CR 103

Chave (41mm) para tensionar a correia dentada do Corsa e Celta.

0.38 kg



CR 113

Extrator do terminal de direção GM: Monza, Kadett e Ipanema e também nos veículos: VW: Santana, Quantum, Gol e Parati 95..., e Mitsubishi - L200

0.82 kg



CR 114

Extrator do terminal da barra de direção GM: Corsa, Celta e Tigra e também nas linhas: VW, FORD, FIAT, e Citroën C3

0.52 kg



CR 117

Ferramenta p/ regulagem do sincronismo do Volante. (Posicionar em PMS) Motor Maxion HS 2.5 / 2.8 e NGD 3.0

0.12 kg



CR 118

Ferramenta p/ Fixação da Engrenagem da Bomba injetora (pino-trava) (Motor Maxion HS 2.5/ 2.8)

0.06 kg



CR 123

Ferramenta para imobilizar a polia dentada da árvore de manivelas dos motores: 1.8 / 2.0 / 2.2 - 8 e 16V GM - Vectra / Astra (exceto mod. GSI)

0.49 kg



CR 123 A

Ferramenta para sacar a polia dentada da árvore de manivelas: Astra / Vectra / Kadett / Monza 1.8 / 2.0 - 8 e 16V (exceto GSI)

0.80 kg



CR 123-B

Ferramenta para imobilizar a polia dentada da árvore de manivelas GM : S-10 2.4 Flex

0.52 kg



CR 138

Sacador do braço Pitman e auxiliar da direção S10 - Blazer. E também na linha MB, Sprinter

2.09 kg



CR 138 C

Extrator de terminal de direção, braço Pitman e Pivô superior (s-10)

1.84 kg



CR 127

Extrator do Pivô da bandeja da suspensão dianteira GM: Kadett, Vectra, Monza, Omega, Corsa e Astra 99... Citroën C3, Picasso Honda Civic e do terminal de direção do Audi A3, Fox, Golf 99... Bora, Eco Sport, Stilo, Palilo, Brava, Dobló, Clio, Scénic, Toyota Corolla e Land Rover.

1.33 kg



CR 136 B

Ferramenta especial p/ travar comando de válvulas (uso no local) GM: Kadett, Monza 1.8 e 2.0 8v, Corsa 1.0 e 1.4, Omega, Vectra 2.0, Meriva 1.8 e Linha FIAT Stilo 1.8 (compressão de molas c/ cabecote ainda montado) ACOMPANHA ACESSÓRIO P/ SER UTILIZADO EM VHC POWER / ECONOFLEX (136 A)

0.35 kg



CR 136 C

Acessório da ferramenta CR 136 B para comprimir as molas de válvulas dos motores GM 1.0 e 1.4 aplicados no Onix e no Prisma (13 em diante).

0.09 kg



CR 141

Sacador e colocador do rolamento do cubo da roda dianteira GM (Monza, Kadett, Vectra 95/96, Corsa) VW (Gol 95...)

3.10 kg



CR 141 A

Sacador e colocador do rolamento da roda dianteira do Corsa e Celta

2.34 kg



CR 141 B

Fuso roscado (280mm) para reposição da ferramenta CR 141 e CR 141-A 255mm x w7/8"x9 Fpp

0.87 kg



CR 153

Ferramenta especial p/ travar o volante do motor no veículo (uso no local) GM: Meriva 8 e 16V /Corsa 1.8 8V e FIAT: Stilo 1.8 8 e 16V, Strada 1.8 8V, Siena 1.8 8V e Palio 1.8 8V (todos equipados com motor Powertrain)

0.36 kg



CR 154

Ferramenta para travar polia do virabrequim nos veículos: Corsa e Meriva, Spin, Cobalt (1.8 - 8 e 16V - Ecotec)

1.22 kg



CR 164

Sacador do volante de direção dos veículos GM: Astra, Vectra, Kadett, Corsa e Omega

0.85 kg



CR 164 A

Par de garras avulsas da ferramenta CR 164

0.20 kg



CR 168

Extrator e Instalador das buchas da suspensão traseira Corsa e Celta

0.12 kg



CR 168 A

Fuso roscado (300mm) para reposição da ferramenta CR 168 191mm x M14 x 2

0.46 kg



CR 155 A

Ferramenta para (des)montar anel trava do conjunto bóia-bomba (combustível) do Corsa

0.45 kg



CR 163

Chave de (60 mm) p/ remoção e instalação da porca de fixação do amortecedor dianteiro na torre da suspensão dos veículos GM Monza, Kadett, Ipanema, Vectra 95/96 e Astra até 99

0.94 kg



CR 183

Ferramenta para sacar a polia do virabrequim dos motores HS MAXION 2.5 e 2.8

0.48 kg



CR 202

Chave Sextavada Intercambiável para aperto da Contra Porca da Cremalheira: Vectra, Corsa, Monza, Kadett

0.17 kg



CR 203

Chave soquete (longo) 36 mm x 3/4" para a porca da homocinética: S10 / Blazer 4x4 e também nos veículos: Tempra, Marea, Brava e Citroën Picasso

0.48 kg



CR 222

Sacador e colocador das buchas do braço longitudinal de controle da suspensão traseira (Transversal) veículos: GM Monza, Kadett, Vectra 97... e Omega

4.30 kg



CR 222 A

A Fuso roscado (330mm) completo para substituição da ferramenta CR 222 190mm x M16 x 2

0.57 kg



CR 223

Chave "L" perfil five lobby com guia de segurança para os parafusos do sensor de luxo de ar (MAS)GM Omega (mod. novo)

0.01 kg



CR 249

Ferramenta especial para soltar a luva ranhurada da caixa de satélite. (cód. GM 90304340) dos veículos Zafira, Meriva, Vectra e Astra 96...

0.78 kg



CR 251

Ferramenta especial para soltar a luva ranhurada da caixa de satélite. (cód. GM 90470588) dos veículos Monza, Kadett Corsa e Astra (antigo)

0.86 kg



CR 264

Chave especial para contra porca da Regulagem da Cremalheira GM: Vectra/ Kadett/ Monza

0.15 kg



CR 281

Jogo de extratores interno (24 e 27 mm) para sacar rolamentos do câmbio GM: Corsa/ Zafira/ Astra/ Meriva. Rolamentos: INA F-235739 eixo de 24mm, e INA F-558683, eixo de 27mm

2.27 kg



CR 296

Alavanca com quadrado de 1/2" para retornar o tensionador da correia poli-v (GM 3.3 V6) CAPTIVA E OMEGA 2005...

0.42 kg



CR 297

Chave soquete sextavado com boca cônica de 33mm com encaixe de 3/4". Para: Pinhão da S-10 F-250, CHEROKEE

0.38 kg



CR 298

Ferramentas para sincronismo (arvore de MANIVELAS) do motor GM 2.8 turbo diesel. NOVA S-10

0.16 kg



CR 298 A

Ferramentas para sincronismo (arvore de COMANDO DE VÁLVULAS) do motor GM 2.8 turbo diesel. 180 cv - 2012...

0.30 kg



CR 298-B

Ferramenta para sincronismo da arvore de comando de válvulas do motor GM 2.8 Turbo Diesel (200cv) 2014...

0.20 kg



CR 302

Chave extraiada de 32 mm para o Refil da tampa do filtro de óleo da motor GM - ECOTEC 2.4

0.14 kg



CR 312

Dispositivos (3pçs) para imobilização dos comandos de válvulas : GM CAPTIVA/ OMEGA V6
0.45 kg



CR 315

Extrator/Colocador das buchas da bandeja superior GM S-10
1.21 kg



CR 316

Jogo de ferramentas para sincronismo do GM Cruze 1.8 / Sonic 1.6 16V
0.97 kg

316 B
verificação do sincronismo das árvores de comando 0.25 kg

316 A
Bloqueio do volante do motor 0.06 kg

316 C
bloqueio do tensor 0.05 kg

316 D/E
Tava das engrenagens de comando de válvulas 0.30 kg



(Confira Kit completo - Seção Kit para Sincronismo de motores)



CR 320

Chave especial longa combinada fixa / 13 estrela porca do tensor da correia do alternador GM: Kadett / Monza / Vectra (antigo)
0.03 kg



CR 330

Jogo de ferramentas para sincronismo da S10 motor Ecotec Flex 2.5 16V 2015... (206 CV)
0.34 kg



CR 341

Jogo de ferramentas para soltar amortecedor GM: Cruze, Camaro, Malibu, Cobalt, Spin, Onix, Sonic, Novo Prisma.
0.32 kg



CR 345

Chave soquete especial com sextavado de 48 mm, encaixe de 3/4" p/ soltar a porca da transmissão S-10 2.5 Ecotec 206 CV Flex afim de trocar o retentor do eixo.
2.13 kg



CR 391

Dispositivo para travar os eixos de comando de válvulas. Motor GM Ecotec 1.4 16v turbo - Cruze e Tracker
0.89 kg



CR 344 - KIT S10

Kit de ferramentas para sincronismo: 180 CV 2.8 turbo Diesel = (CR 298 + CR 298-A) 200 CV 2.8 Turbo diesel = (CR 298 + CR 298-B) 206 CV 2.5 Ecotec = (CR 330) composição das ferramentas: CR 298 / CR 298-A / CR 298-B / CR 330
1.43 kg



MULTIMARCAS

7

Veja também Kits para Sincronismo - Seção 9



CR 14

Chave tipo soquete longa (95 mm) p/ aperto dos parafusos do cabeçote / amortecedor. Citroën, Peugeot e Renault (TORX E12)
0.12 kg



CR 14 A

Chave soquete Extra longo (180mm) com encaixe de 1/2 para os parafusos do cabeçote BMW SÉRIE X (TORX E12) Usar em conjunto com CR 15-A (TORX E 10)
0.25 kg



CR 15 A

Chave soquete longa (180 mm) para os parafusos do cárter Motor Renault, Peugeot e Citroën (TORX E10)
0.23 kg



CR 20 B

Chave soquete Extra-longo (180mm) (TORX T-55) cabeçote BMW. Utilizar em conjunto com CR 124-A (TORX T60)
0.22 kg



CR 24

Chave tipo soquete longa (100 mm) p/ aperto dos parafusos do cabeçote: Linha Citroën e Peugeot (TORX T55)
0.13 kg



CR 27

Chave tipo soquete longa (135mm) multidentada de 12mm p/ cabeçote Toyota Corolla 2003... 1.6 e 1.8 16V
0.15 kg



CR 42

Chave para: cabeçote Peugeot 206 1.6 16V. E também na linha GM (TORX E14)
0.30 kg



CR 124 A

Chave tipo soquete Extra-longa (180mm) (TORX T-60) CABEÇOTE BMW. Utilizar em conjunto com CR 20 B (TORX T55)
0.25 kg



CR 128 A

Chave de velas 14mm extriada (Curta 80mm) encaixe 3/8" Peugeot / Citroën Motor THP/ BMW
0.07 kg



CR 132

Chave soquete especial com estriado de 9,8 mm para parafusos do cabeçote Toyota Corolla até 2003
0.13 kg



CR 140 G

Ferramenta para travamento e fixação das polias de comando Renault 2.0 16v (Megane e Scenic)
0.78 kg



CR 152

Chave para a Porca do Amortecedor dianteiro: Renault Clio, Mégane e Scenic e Peugeot 206 e 307 Citroën C3 (Usar com CR 54)
0.36 kg



CR 155

Ferramenta para (des)montar conjunto bóia-bomba (combustível) Renault e também utilizada nas linhas: Fiat e FORD
0.51 kg



CR 165

Chave "L" c/ encaixe 28mm para cárter Renault, Peugeot, Citroën 1.6 16V - C3 e Picasso
0.23 kg



CR 169

Ferramenta para soltar os coxins do motor dos veículos Peugeot 206
0.32 kg



CR 169 A

Ferramenta para soltar os coxins do motor dos veículos Citroën Picasso
0.47 kg



CR 182

Ferramenta especial com sextavado de 50 mm, para fixar ou soltar a polia da árvore dos motores Honda: Civic e Accord. Usar c/ G100 17x3/4" ou G100 19x3/4"
1.06 kg

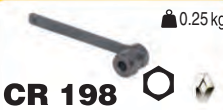

CR 198

Chave Especial Sextavada de 28 mm para Travar a Polia do Alternador (Valeo 439431) Renault, Scenic, Kangoo e Clio 16 V Fabricados a partir de 2000
0.25 kg



CR 203

Chave soquete longo de 36 mm x 3/4" para a porca da homocinética: Citroën Picasso e também utilizada nas linhas: GM e FIAT
0.48 kg



CR 245

Ferramenta para alinhar o pedal de embreagem do New Civic
0.07 kg



CR 140 A

Tensionador
Tipo D7D: Clio,
Kangoo, Twingo
0.14 kg



CR 140 D
Ferramenta para travamento
e fixação das polias de
comando (Renault 1.6 (16V)
Clio/Mégane/Scenic)
0.65 kg

SINCRONISMO



CR 140 B
Ferramenta para
posicionamento do
virabrequim. Renault:
Clio, Megane,
Scénic (1.6 - 16V)
0.07 kg



CR 140 C

Ferramenta para posicionamento
das árvores de cames em PMS
(Renault 1.6/2.0 (16V)
Clio/Mégane/Scenic)
0.34 kg

Peças Avulsas



CR 140 E

Ferramenta para
posicionamento do virabrequim.
Renault: Megane,
Scénic (2.0 - 8 e 16V)
OBS.: Clio 1.0 / 1.6 esta ferramenta
é utilizada no volante do motor
0.65 kg



CR 140 F

Ferramenta para travar o
volante do motor
Renault 1.0, 1.6 e 2.0 / 16v
(Clio, Megane e Scenic)
0.17 kg

CR 235 B



Ferramenta para referência da polia da árvore de manivelas
e sincronismo do motor. Veículos: CITROËN Berlingo, Xantia
e Xsara. PEUGEOT 306, 405, 406, 806 e Partner
(Motores 1.8 e 2.0 8v, 2.0 16v)
0.35 kg

CR 244

Conjunto de ferramentas
para extrair e instalar
as buchas da
suspensão traseira
e dianteira.
HONDA Civic 2001...
(usar em prensa
hidráulica)
5.54 kg



CR 246
Ferramenta para aperto
da caixa de direção
(29 mm)
HONDA Civic
0.17 kg



CR 247

Ferramenta para segurar e
apertar a contra porca da caixa
de direção (40 mm)
HONDA Accord / Civic / CRX /
Legend / Odyssey e Fit
0.38 kg



CR 294

Chave 'T' longa (385 mm)
para parafusos de cárter
do Corolla / Honda
Civic / Fit / Golf
0.47 kg



CR 303

Ferramenta para
destacar o
amortecedor
(dianteiro)
da manga do
eixo. RENAULT:
MÉGA/NE/
SCÉNIC.2006...
2.35 kg



CR 306

Ferramenta para
a introdução das
buchas da barra
estabilizadora
RENAULT:
CLIO/SANDERO/
LOGAN/KANGOO
1.26 kg



CR 314

Chave extriada de 27mm
para o Refil da tampa do filtro
de óleo dos veículos:
PEUGEOT e CITROËN
10.0 1.6 2013...
0.11 kg



CR 317

Chave soquete especial
perfil 10 lados para os parafusos
dos braços da suspensão traseira:
HONDA Civic 1.7
0.28 kg



CR 324 A

Ferramenta de alinhamento da
polia da árvore de manivelas nos
motores 2.0i Turbo:
Range Rover Evoque / Jaguar
0.44 kg



CR 324 B

Ferramenta de alinhamento do
sensor da posição da árvore de
manivelas nos motores 2.0i Turbo:
Range Rover Evoque / Jaguar
0.25 kg



CR 324 C

Ferramenta para travar o volante
dos motores 2.0i Turbo:
Range Rover Evoque / Jaguar
0.57 kg



CR 355

Chave tipo soquete (170mm)
Cabeçote HYUNDAI: TUCSON (6cc)
AZERA/ SANTA FÉ/ VERA CRUZ
Estríada- fêmea de 12 mm
0.35 kg



CR 364

Ferramenta para retirar e instalar o
bico injetor de combustível. Veículos :
BMW Motores :N20/N55
0.70 kg



CR 373

Ferramenta para
travar o volante
do motor BMW
(motor fora
do veículo)
0.12 kg



CR 375

Chave estríada de 36 mm comprimento de 235mm x 30° para soltar a
tampa do filtro de óleo do motor N13- BMW / MINI COOPER.
0.26 kg

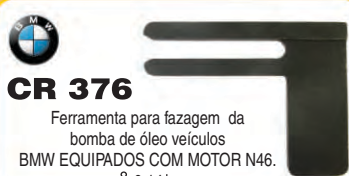

CR 376

Ferramenta para fazagem da
bomba de óleo veículos
BMW EQUIPADOS COM MOTOR N46.
0.14 kg



CR 381

Chave soquete especial
Vazado (sextavado interno
18mm x sextavado externo de
22mm- altura 60mm)
Para porcas de amortecedores
-Uso universal-
0.10 kg



CR 381 A

Chave soquete especial Vazado
(sextavado interno 21mm x
sextavado externo de 22mm-
altura 77mm)
Para porcas de amortecedores
-Uso universal-
0.18 kg



CR 382

Par de ferramentas rosca
(internas) M27x1,5 e
M24x1,5 para a introdução
da ponta do eixo nos
veículos BMW
1.28 kg



CR 383

Cave soquete com perfil especial
(6-lados) 22,10mm com furo guia
(11,25mm) para o Parafuso-Válvula
dos comandos dos veículos
Mercedes equipados co motor:
M270,M271,M274 e M 133
0.12 kg



CR 385

Ferramenta para introduzir
o anel de TEFLON nos bicos
injetores (a fim de não danifica-los)
BMW /MERCEDES Adaptadores
(7,98X9,72mm) (7,78x9,52mm)
(8,27x10,00mm)
0.13 kg



CR 411

Chave sextavada
41mm x 1/2" para npivô da
suspensão : PEUGEOT e CITROËN
0.33 kg



CR 412

Ferramenta para retirar e instalar a bucha
inferior do coxim do motor dos veículos
das linhas CITROËN e PEUGEOT ,
(Bucha com furo de 65 a 70mm)
2.90 kg



CR 412 A

Fuso rosado (173mm) completo para
substituição da ferramenta CR 412 90mm x M10 x 1,5
0.21 kg



CR 413

Chave soquete vazada PERFIL ESPECIAL
de 18mm com sextavado externo de 21mm
comprimento de 100mm para porca dos
amortecedores eletrônicos EDC
0.18 kg



CR 417

Jogo de ferramentas (2pçs) Soquete sextavado vazado de 16mm interno x 20 mm externo + chave L de 7mm para haste dos amortecedores dianteiro do RENAULT KWID.

0.12 kg



CR 447

Conjunto de ferramentas para posicionar em sincronismo os motores CHERY ACTECO 1.3 / 1.6 e 2.0 (ambos 16v) FACE/CIELO e TIGGO

0.12 kg



CR 475

Chave tipo soquete longa (120mm) estriado interno de 14mm e encaixe "ESTRELADO" 1/2" 8 pontas. Parafusos do cabeçote dos veículos Honda: New Civic - CRV - Accord

0.12 kg

Diesel Universal

8.1



CR 127-A

Extrator de Pivos e Terminais de Direção para utilitários leves

2.91 kg



CR 131

Chave especial com estriado de 17 mm para o cano do injetor de diesel

0.13 kg

1/2



CR 138

Sacador do braço Pitman e auxiliar da direção S10-Blazer / Sprinter

2.09 kg



CR 138 A

Extrator do terminal do braço Pitman da direção da Mitsubishi L200 e para uso também Mercedes Benz (Utilitários linha leve)

1.17 kg



CR 138 B

Extrator do braço Pitman de direção Mercedes Bens Ônibus e Caminhões

2.00 kg



CR 187-A

Extrator para bico injetor do sistema COMMON RAIL (rosca M8 x 1 mm) com adaptadores M12 e M14 x 1,5 mm

1.43 kg



CR 192

Ferramenta especial para levantar os tuchos de bombas injetoras modelo 7000

0.08 kg



CR 194

Ferramenta especial para levantar os tuchos de bombas injetoras modelo 3000

0.08 kg



CR 218

Ferramenta para soltar e apertar o bujão central de bomba injetora VE (1/2")

0.25 kg



SCANIA

Mercedes Benz / Scania

8.2



CR 131-A

Ferramenta des(montar) a porta injetor dos motores OM447/449

0.26 kg



CR 131-B

Ferramenta para soltar a porca de fixação do porta injetor dos motores: OM447/449

0.15 kg



CR 131-C

Ferramenta des(montar) o porta injetor dos motores OM353 / 355 / 364 / 366

0.098 kg



CR 184

Ferramenta tipo soquete para soltar o porta válvulas da bomba injetora Bosch, Mercedes (OM 447/449), MWM série 10 e Scania 113/114/122

0.15 kg



CR 184 A

Chave especial (reta) para soltar ou segurar o porta válvulas da bomba injetora Bosch, Mercedes (OM 447/449), MWM série 10 e Scania 113/114/122

0.48 kg



CR 185

Chave tipo soquete longo (100 mm) multidentada de 16 mm para parafusos do volante do motor Mercedes Benz OM 904 / 906 / 924 / 926

0.16 kg



CR 186

Ferramenta para soltar a camisa do porta injetor Mercedes: OM 314, 352, 355, 364, 366

0.20 kg



CR 189

Chave soquete longo com sextavado de 30 mm para o porta injetor do motor OM 314/352/355/364 e 366

0.35 kg



CR 190

Chave soquete longo com sextavado de 28 mm para o porta injetor do motor Scania: 94 / 113 / 114 e 124 (mecânica)

0.35 kg



CR 199

Chave tipo soquete longo com octagonal especial de 39 mm. para a porca do estator da UI (Scania Eletronica)

0.36 kg



CR 1010 A

Dispositivo para testar o Bico injetor do Mercedes Benz - Eletronic

0.67 kg



CR 191 A

Chave soquete longo com Sextavado de 17 mm (alta resistência)

0.47 kg



CR 191 B

Chave soquete longo com sextavado de 19 mm (alta resistência)

0.44 kg

USADAS EM CONJUNTO NA REMOÇÃO DOS PARAFUSOS DA COROA E CAIXA SATÉLITES MERCEDES BENZ



CR 410

Ferramenta Especial tipo soquete estriado fêmea de 11 lados 10mm com sextavado de 11mm x 25 comprimento, para girar os acionadores da pinça de freio da linha Mercedes Benz (utilitários) ACCELO 915 / 1938 / 1622/1944/O500/AXOR: 1933/2035/20402044/2533

0.02 kg



CR 262

Chave especial para aperto da porca (encaixe 6mm) engrenagem do avanço da bomba injetora (MERCEDES-352) / MWM 226/ 229 / F1000 / 4000 / VW 11130 / 6.90

0.36 kg



CR 401

Ferramenta especial para soltar o regulador da bomba Injetora RSV (motor MWM)

0.12 kg



CR 402

Ferramenta especial para soltar o regulador da bomba Injetora RQV (Motor Mercedes Benz)

0.14 kg



CR 263



Chave especial para aperto da porca (encaixe 3,7mm) dos reguladores da bomba R Q (V) - A e P

0.33 kg

8.3 Maxion

 **CR 86**
Chave especial (36 mm) para retenção do eixo do ventilador do motor HS Maxion 2.8 e Ranger 98 a 2005

 **CR 87**
Chave especial de (32 mm) p/ retenção do eixo do ventilador do motor HS 2.5 MB Sprinter, Ranger, S10, Blazer (diesel), Land Rover e F 1000 ano 97

 **CR 87 A** $\frac{1}{2}$
Chave especial (36 mm) para retenção do eixo do ventilador do motor HS Maxion 2.8  0.43 kg

 **CR 183**
Ferramenta para sacar a polia do virabrequim motor HS Maxion 2.5 / 2.8  0.48 kg

 **CR 117**
Ferramenta para regulagem do sincronismo do volante Posicionar em PMS motor HS Maxion 2.5 / 2.8 e NGD 3.0  0.12 kg

 **CR 118**
Ferramenta para fixação da engrenagem da bomba injetora (pino trava) do motor HS Maxion 2.5 / 2.8  0.06 kg

 **CR 224**
Ferramenta para travar comando de válvulas do motor Maxion NGD 3.0 (eletrônico) Ranger 2006  0.09 kg

8.4 MWM

 **CR 89**
Chave tipo soquete longa (90mm), multidentada de 14 mm para parafusos da polia do virabrequim e volante do motor MWM Sprinter, Silverado, e S10 2.8 (diesel); parafuso do cabeçote do motor Detroit diesel 425 IDI Dakota e trator com motor Detroit diesel D704 LE  0.31 kg



 **CR 89-A / M14**
Chave "L" longa (200mm) multidentada de 14mm  0.13 kg

 **CR 188**
Chave soquete longo com sextavado de 24 mm para o porta-injetor do motor MWM série 10  0.29 kg

 **CR 205**
Sacador da engrenagem da bomba injetora (com ou sem avanço) nos motores: MWM série 10, 229 e X12 (com sacador multifuncional)  2.80 kg

 **CR 206**
Ferramenta para instalar e sacar a camisa do motor MWM série 10 e 229  5.45 kg

 **CR 207**
Ferramentas de posicionamento em PMS (Comando de Válvulas) motor MWM, Sprint 4 e 6 Cil.  1.14 kg

 **CR 207 A**
Ferramenta de posicionamento em PMS (no volante) dos motores MWM Sprint 4 e 6 cilindros, e internacional NGD 3.0 (S-10 / Blazer, F250, Frontier, Silverado)  0.08 kg

 **CR 208**
Ferramenta de bloqueio da cremalheira. Motor MWM Sprint 4 e 6 Cil  0.54 kg

 **CR 209**
Ferramenta para comprimir e (des)montar as molas das válvulas do motor MWM: série X10 / X12 / 229 / Sprint 4 e 6 Cil e também nos motores Maxion 2.5 / 2.8 / NGD 3.0 e MS 3.9  1.17 kg

 **CR 210**
Ferramenta para remover a tampa de acesso a engrenagem intermediária (tampa traseira do cabeçote) motor MWM Sprint  0.52 kg

 **CR 211**
Dispositivo para regular o ponto de injeção da bomba injetora rotativa (Ve). Suporte para ser utilizado com relógio comparador Acompanha 2 pçs: uma com rosca M8 para motores MWM 229 e X10. E outra com rosca M10 para motores MWM Sprint / L200.  0.25 kg

8.5 VANS e PICK-UPS

 **CR 131 D**
Chave especial com estriado de 17mm para os tubos de pressão dos injetores: Ducato, Boxer e Jumper  0.35 kg

 **CR 219**
Extrator de Cubo de Rodas (Aro 15) Ducato, Boxer e Jumper  4.77 kg

 **CR 225**
Ferramenta para Travamento da Mola do Tensor Inferior. (Usada para Troca de Correia Dentada) Veículos: Ducato, Boxer e Jumper  0.04 kg

 **CR 226 B**
Ferramenta para extrair o eixo do comando da embreagem. Aplicação: DUCATO, BOXER, JUMPER (câmbios MG, ML GU) 2.8 8V  0.48 kg

 **CR 227**
Ferramenta Especial para Fixação da Bomba D'Água ao Bloco do Motor Veículos: Ducato, Boxer e Jumper  0.27 kg

 **CR 228**
Ferramenta Especial para Introduzir a Bucha Posterior da Mola da Suspensão Traseira. Veículos: Ducato, Boxer e Jumper  1.07 kg

 **CR 229**
Ferramenta especial para soldar e apertar a porca / haste do amortecedor dianteiro Ducato, Boxer e Jumper  0.40 kg

 **CR 231**
Ferramenta Especial para Travar Polia do Eixo de Comando de Válvulas. Ducato, Boxer e Jumper  0.73 kg

 **CR 238**
Pino para travar polia dos órgãos auxiliares (utilizada na troca da correia dentada)  0.08 kg

 **CR 239**
Ferramenta para introduzir pista externa e rolamento ao cubo anterior (utilizada com auxílio de prensa hidráulica) Ducato, Boxer e Jumper  2.19 kg

 **CR 241**
Chave soquete $\frac{3}{4}$ " para porca ranhurada da engrenagem da 5ª marcha Ducato, Boxer e Jumper  0.36 kg



0.95 kg

CR 60 / 60 A

Jogo de chaves de garras para soltar a porca (KM-8) ranhurada do eixo do cubo da roda traseira dos veículos: Vans / Utilitários (linha Asiática)



0.38 kg

CR 242

Chave soquete (longo) com sextavado de 27mm, para o sensor de pressão do combustível no COMMON RAIL. Aplicação: Ducato, Boxer e Jumper / motores Maxion NGD 3.0 e MWM: X12, Sprint eletrônico



CR 243

Pino guia para centragem do disco da embreagem Ducato, Boxer e Jumper

0.43 kg



0.23 kg

CR 293

Chave Soquete Pentagonal para o parafuso de ajuste das pinças de freio traseiras. Renault Master.



CR 299

Ferramentas para sincronismo (árvore de MANIVELAS) dos motores 2.3 e 3.0 16v BOXER DUCATO JUMPER (2010...) e IVECO DAILY

0.21 kg



0.73 kg

CR 301

Jogo de ferramentas para sincronismo (árvore de comando) dos motores 2.3 e 3.0 16v Boxer, Ducatto, Jumper (2010...) e Iveco Daily



2.78 kg

CR 230

Ferramenta especial para extração e introdução das buchas do braço oscilante Ducato, Boxer / Jumper



0.16 kg

CR 76 / 10mm

Chave soquete longa (140mm), com sextavado de 10mm para parafuso do cabeçote da Mitsubishi L-200 e no motor MWM Sprint.



CR 399

Jogo de dispositivos para sacar o cubo da roda dianteira do rolamento (Toyota Hilux) Utilizar em prensa hidráulica

8.85 kg



com rolamento de alívio

5.07 kg

CR 284

Extrator e colocador dos pivôs: superior e inferior dos veículos Renault Master / MB Sprinter (uso no local)



CR 284 A

Jogo de fuso roscado (220mm) com porcas e rolamentos para substituição CR 284 1 40mm x M18 x 2

1.22 kg



CR 285

Sacador da bucha (no chassi) de Torção: Mitsubishi L-200

2.74 kg



CR 286

Sacador da bucha do feixe de molas: Toyota Hilux / Nissan Frontier / Mitsubishi L-200

1.79 kg



2.74 kg

CR 287

Sacador das buchas da bandeja dianteira: Toyota Hilux Obs.: A BUCHA MAIOR DA BANDEJA SUPERIOR deverá ser retirada em prensa pois o copo da ferramenta não se adapta ao tamanho da bucha



0.65 kg

CR 287 A

Fuso roscado com porcas e arruelas para substituição CR 287



CR 354

Ferramenta para soltar e apertar a tampa plástica ranhurada do refil do filtro de combustível: BOXER / JUMPER / DUCATO 2.3 (2010...)

0.77 kg



CR 359

Martelo deslizando, especial para extrair e colocar homocinéticas em utilitários. Medidas de roscas: M24x1,5mm, M28x1,5mm e M33x1,5mm

0.12 kg



0.12 kg

CR 236

Ferramenta para travar comando de válvulas e polia do virabrequim do Renault Master DCI 2.5 (G9U) para troca da correia dentada



CR 361

Jogo de ferramentas p/ sincronismo do motor (M9T-672) do veículo Renault Master III 2.3 D dCi 2010...



0.49 kg



CR 370

Chave tipo soquete tubular longo (300mm) 43mm X 3/4" para a remoção da porca do eixo piloto o câmbio dos veículos: HYUNDAI HR e KIA K2500



1.05 kg



CR 378

Chave tipo soquete com encaixe 1/2" x 55mm com perfil especial 11,26 mm (ribe) Para os parafusos do volante do motor Renault Master 2.3

0.80 kg



0.12 kg

CR 379

Chave tipo soquete com encaixe 1/2" x 55mm com boca (sextavado interno) especial 27/64" que corresponde a 10,71mm. Para os parafusos das biélas do motor Renault Master 2.3



0.35 kg

CR 384

Ferramenta para sacar a válvula reguladora de pressão de combustível do sistema Common Rail



CR 360

JG de chaves de boca Meds: 29,40 e 34,50 mm com encaixe quadrado de 1/2" p/ a remoção e aperto da válvula reguladora de pressão sistema Common-Rail (BOSCH 0 281 006 074) VW TDI 2.0 AMAROK, IVECO DAILY / DUCATO

0.22 kg



CR 422

Ferramenta especial com estriado de 13mm para porca inferior da bomba injetora dos veículos: IVECO- Daily e Fiat DUCATO

0.18 kg



CR 240

Suporte para remoção e recolocação do câmbio. (Este suporte é utilizado com auxílio de um macaco jacaré.) Aplicação: Ducato, Boxer e Jumper



10.9 kg

8.6

Bicos Injetores

CR 450

CONJUNTO COM 25 FERRAMENTAS PARA MANUTENÇÃO EM BICOS INJETORES E BOMBAS DE ALTA PRESSÃO. (BOSCH, DENSO SIEMENS)



CR 99A
Extensão curta (70mm) com encaixe de 1/2"



CR 178
Chave L com perfil especial (5 pontas - 3,9mm) com guia de segurança (furo de 3,9mm) para parafusos do solenóide da unidade injetora BOSCH PLD



CR 311
Ferramenta para sacar a válvula do porta injetor do COMMUN RAIL, do bujão UI BOSCH



CR 403
Chave com perfil especial 12 lados 27 mm Solenóide do bico injetor eletrônico BOSCH Euro V

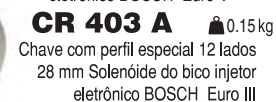

CR 403 A
Chave com perfil especial 12 lados 28 mm Solenóide do bico injetor eletrônico BOSCH Euro III



CR 423
Dispositivo especial para manutenção e reparos em bicos injetores da marca DENSO. (Deve ser utilizado com auxílio de um torno de bancada)



CR 427
Ferramenta para sacar a porca interna dos bicos injetores DENSO- EURO III e EURO V

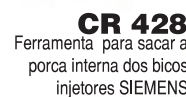

CR 428
Ferramenta para sacar a porca interna dos bicos injetores SIEMENS



CR 435
Chave soquete (6-lados) 15mm com guia para a porca da capa dos porta injetores: DENSO SIEMENS e DELPHI - EURO III e V



Chave de boca fixa para porca do solenóide dos injetores



CR 429
25mm



CR 430
27mm



CR 431
28mm



CR 432
29mm



CR 433
Chave soquete (8-lados) 16 mm com guia para a porca da capa dos porta injetores BOSCH - EURO V



CR 434
Chave soquete (8-lados) 17,5 mm com guia para a porca da capa dos porta injetores BOSCH - EURO III



CR 438
Suporte para relógio comparador para medir o curso da esfera dos Injetores BOSCH - EURO V (rosca M26x0,75mm)



CR 436
Chave soquete (6-lados) 14mm com guia para a porca da capa dos porta injetores: DENSO EURO III e V



CR 437
Ferramenta para introduzir o vedador do injetores BOSCH (7,5 e 8 mm)



4,65 kg



CR 439
Suporte para relógio comparador para medir o curso da esfera dos Injetores EURO III (rosca M27 x 1 mm)

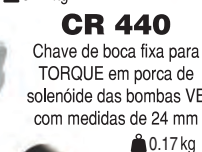

CR 440
Chave de boca fixa para TORQUE em porca de solenóide das bombas VE com medidas de 24 mm



CR 441
Chave soquete Perfil 16 x 12mm para válvula reguladora de pressão da bomba CP4 BOSCH



CR 442
Chave soquete Perfil 12 x 10mm para válvula reguladora de pressão da bomba: DENSO HP3 e BOSCH VE



CR 443
Chave soquete com extrido interno (13mm - 31 dentes) para as conexões de entrada e retorno nas bombas CP3 utilizadas na RENAULT MASTER



CR 444
Chave soquete MULTIDENTADA de 12 mm com guia de 19mm para sacar a porca interna do injetor BOSCH - EURO V



CR 445
Chave soquete Perfil especial (10,30mm) 6 cantos (tipo torx) para soltar o bujão da válvula de aspiração do cabeçote da bomba DENSO



CR 187-A
Extrator para bico injetor do sistema COMMON RAIL (rosca M8 x 1 mm) com adaptadores M12 e M14 x 1,5 mm



CR 460
Dispositivo (FIXADOR) para montar e desmontar os bicos injetores BOSCH Utilizar em torno de bancada - (morsa)



CR 187
Extrator de bico injetor eletrônico para: linha Mercedes Benz e MWM: série 10 e 229 Sprint



CR 363B
Extrator dos bicos injetores SPRINTER CDI Rosca M27X1 (fêmea) e Ranger Rosca M25x1 (macho)



CR 363 A
Carretel avulso da ferramenta CR 363 M27 X 1mm

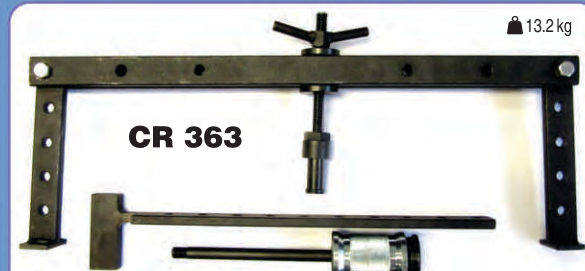

CR 363
Dispositivos para retirar bico injetor eletrônico. Carretel Rosca M27 X 1mm. Sistema (sacador com rosca) em linha, ou individual no sistema (à percussão) Acompanha adaptador para Renault Master (apoiar na caixa seca do câmbio). OBS: Os bicos devem ser de rosca M27 X 1mm e estar sem o solenóide, em condições normais.

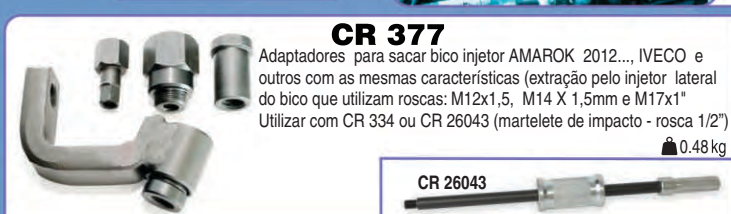

CR 377
Adaptadores para sacar bico injetor AMAROK 2012..., IVECO e outros com as mesmas características (extração pelo injetor lateral do bico que utilizam rosca: M12x1,5, M14 X 1,5mm e M17x1") Utilizar com CR 334 ou CR 26043 (marteleto de impacto - rosca 1/2)



CR 26043





CR 325 A KIT

Ferramentas para sincronismo dos veículos equipados com motores: N12 / N16 para as versões de motores aspirados, com valvetronic e N13 / N18 para motores turbo. Com valvetronic. BMW: 114i / 116i / 118i / 316i / 320i (1.6) 16v 2011.... MINI COOPER: S-11..14 Cabrio- 11..15, Coupe-12..15, Roadster-12..15, Clubman-11...14, Countryman-11..15

📦 2.39 kg



CR 333 KIT

Ferramentas para sincronismo: BMW modelos: 116 / 118 / 120 / 316 318 / 320 / Z4/ x1 MOTORES: N40 / N42 / N45 N45T / N46



📦 0.81 kg



CR 335 KIT

Kit ferramentas (3 pçs): alinhamento do comando de válvulas, pino de sincronismo, ferramenta de pré esticamento da corrente de distribuição. Veículos BMW 6 cil. motores : M40/ M42 / M44 / M50 / M52 / M52TU / M54 8 CIL: M60 / M62 (2 cabeçotes)



📦 1.19 kg

CR 335 A

Ferramenta para configuração das arvores de Cames. BMW 6 cil. com duplo vanos. Motores: M54, M56, S50US, S52US





📦 1.11 kg

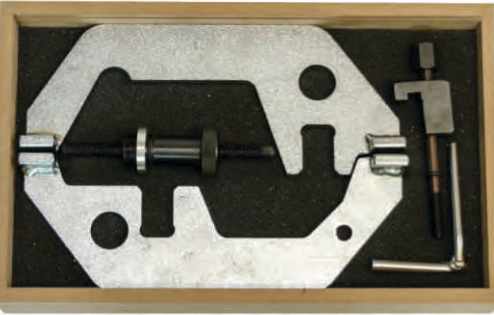

CR 358

KIT de ferramentas para sincronismo dos veículos BMW 545, 645, 745, X-5 8cc equipados com motores: N62 / N73



📦 2.57 kg

CR 349 KIT

KIT de ferramentas para sincronismo dos veículos BMW equipados com motores: 2.5 e 3.0 6cil.

- N51 / N52 / N52K / N55 = (configurador prata-1)
- N53 / N54 ASPIRADO = (configurador prata-2)
- N53 / N54 TURBO, injeção direta sem valvetronic = (configurador azul)
- N20 / N26 4 cil. 2.0 TWIN POWER FLEX TURBO = (configurador preta)



📦 8.79 kg



CR 366 KIT

KIT de ferramentas para sincronismo dos veículos BMW X-5 / X-6 3.0 DIESEL equipados com motores: N47 / N57



📦 1.08 kg



CR 367

KIT de ferramentas para sincronismo dos veículos BMW X-5 4.4 2009.../ X-6 4.4 2009.../ M-5 4.4 2011.../ M-6 4.4 2012.... equipados com motores: N63 / S63 / N74



📦 2.41 kg

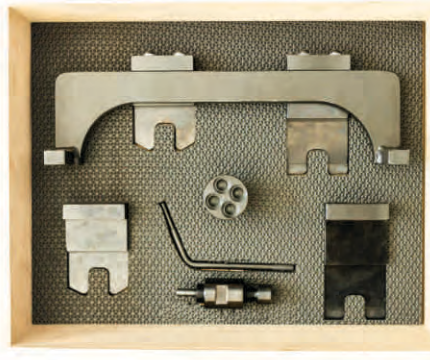

CR 396 KIT
 KIT de ferramentas para sincronismo dos veículos BMW equipados com motores:
 B 38-1.5-12V-3Cil /
 B 48-2.0 16V 4Cil /
 B 58-3.0 24V 6Cil



7.83 kg



CR 396 A
 Ferramenta para sincronismo dos eixos balanceadores do virabrequim veículos BMW equipados com motores: B 48-2.0 16V 4Cil



2.73 kg



CR 426
 Jogo de ferramentas para colocar as molas do conjunto VALVETRONIC - BMW



1.22 kg



CR 383 KIT
 Kit de ferramentas para sincronismo dos motores Mercedes 270 / 274 / AMG 133 (1.6 e 2.0 TURBO) 2012... Motor 271 até 2011



2.07 kg



CR 393 KIT
 Kit de ferramentas para sincronismo dos motor 156 MERCEDES C-CLASS 6.2 C63 AMG 2007 a 2011



1.61 kg

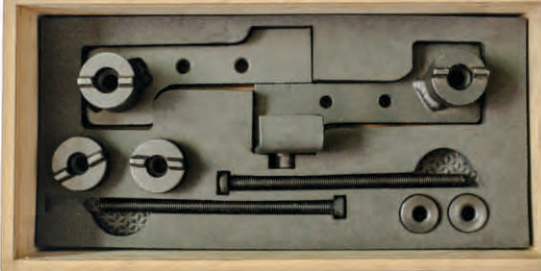

CR 270 KIT
 Ferramenta para posicionamento das árvores de Cames em PMS veículos Volvo (com acionamento de correia) motores: 6294-T / 5254-T / 5234-T / 5244-S / 5234-S / 5204-T / 5202-FS. modelos: C-70 / S-40 / S-60 / S-70 / S-80 / V-50 / V-70 / XC-70 / XC-90 / 850 / 960



1.86 kg



CR 337 KIT
 Kit de ferramentas (4pcs) para fazagem e sincronismo do motor B 63245 que equipam os veículos: VOLVO XC 90 3.2 2010.... Land Rover: Freelander 2 - 2006...





4.71 kg



CR 395 KIT
 Kit de ferramentas para sincronismo dos veículos VOLVO :T4 e T5 : Modelos S-60/V-60/70/S-80 (1.6-motor B4164T4) e S-60 e XC-60 (2.0-motor B4204T4/5/6/7) 2006....2013

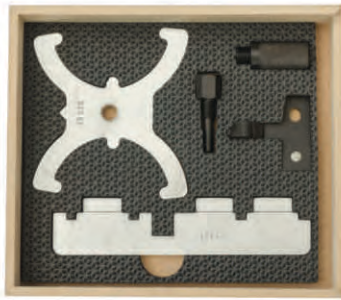

8.30 kg



CR 395 A

Ferramentas para sincronismo dos veículos VOLVO :T4 e T5 :
Modelos S-60/V-60/70/S-80 (1.6-motor B4164T4)

📦 1.26 kg



CR 395 B

Ferramentas para sincronismo dos veículos VOLVO :T4 e T5 :
Modelos S-60/V-60/70/S-80 (1.6-motor B4164T4) e S-60 e XC-60 (2.0-motor B4204T4/5/6/7) 2006.....2013



📦 1.39 kg



CR 400 KIT

KIT de ferramentas para sincronismo:
VOLVO
Série 80 motor
B4204 T11 2.0



📦 7.85 kg



CR 408

Ferramenta para regular a posição dos comandos de válvulas a fim de mantê-los em posição PMS para a troca da polia inferior, evitando assim o desalinhamento do sincronismo. Volvo motor B4204 T4/5/6/7 2.0 turbo 2006 ... 2013. Land Rover Evoque equipados com o mesmo motor.

📦 0.16 kg



CR 324



Conjunto de ferramentas para sincronismo: Ford Fusion EcoBoost / Focus Duratec 2.0L
Range Rover Evoque 2.0 Si 4 2001 a 2014

📦 2.73 kg

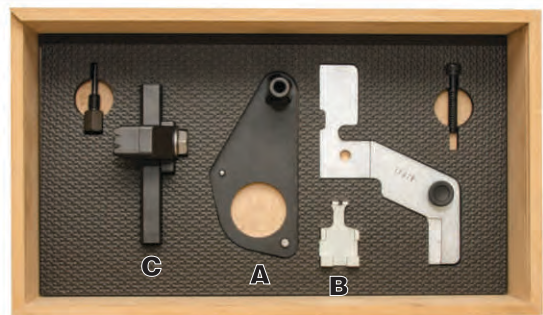

CR 324 KIT

Kit de ferramentas para sincronismo nos motores 2.0l Turbo:
Range Rover Evoque / Jaguar (CR 324 A / B / C)



📦 2.73 kg

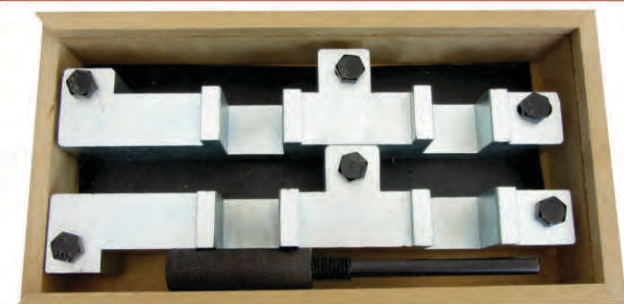

CR 346 KIT



Kit de ferramentas para fasagem e sincronismo do motor 368-DT que equipam os
veículos: Range Rover: 3.6 TD V8 (2006 a 2011)

📦 3.80 kg



CR 356

Ferramenta p/ posicionar o disco de sinal do sensor de rotação
Discovery III 2.7 e IV 3.0 Motores TDV6 e Range Rover 3.6 TDV8



📦 0.66 kg



CR 357 KIT

KIT de ferramentas para sincronismo: LAND ROVER 2.7 e 3.0
Motores 276 DT e 306 DT, 2009.



📦 2.57 kg



CR 369 KIT

Jogo de ferramentas para sincronismo motor DURATORQ TURBO DIESEL-CI:
Ford Ranger 2.2,2.4 (4cc) e 3.2 (5cc) / Transit 2.2,2.4 (4cc) / Troller T4 3.2 (5 cc).
e Land Rover Defender 2.4



📦 0.68 kg

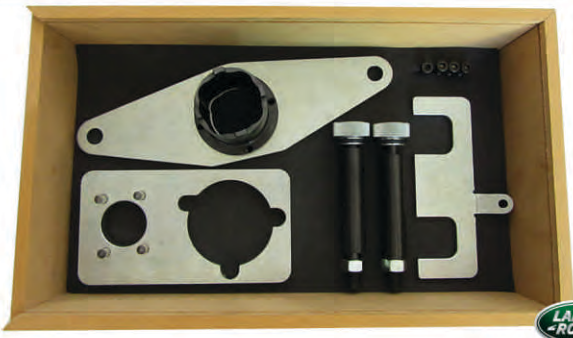

CR 463 KIT

KIT de ferramentas para sincronismo : RANGE ROVER DISCOVERY e
EVOQUE SD4, JAGUAR AJ200 204DT 2.0 DIESEL



📦 2.86 kg



CR 463 A

Ferramenta para sincronismo dos eixos balanceadores do virabrequim veiculos
RANGE ROVER DISCOVERY e EVOQUE SD4 , JAGUAR AJ200 204DT 2.0 DIESEL
OBS: PARA CORRETA UTILIZAÇÃO DESTA FERRAMENTA O MOTOR DEVERÁ
ESTAR NA POSIÇÃO PMS



📦 2.62 kg

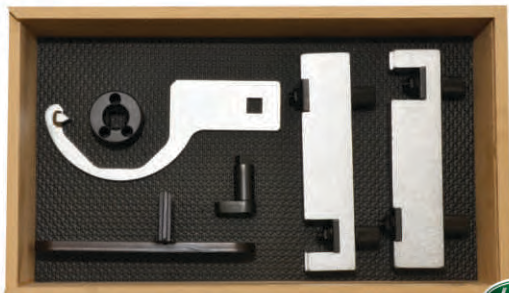

CR 404 KIT

Kit de ferramentas para sincronismo Land Rover Supercharger/
Range Rover 5.0T - Jaguar X-150-250-351



📦 4.84 kg

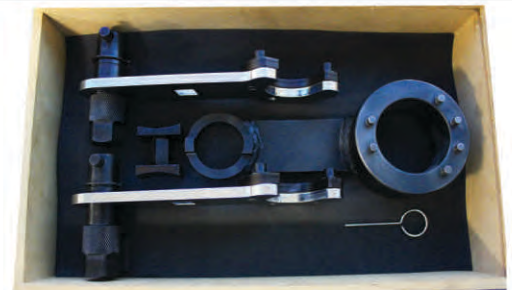

CR 472 KIT

KIT de ferramentas para sincronismo : LAND ROVER FREELANDER 1 (1999-2005) /
KIA CARNIVAL e SEDONA (MOTOR K V6 2.5- CORREIA)



📦 2.85 kg



CR 07 S

Rosca M14

CR 07 AS

Rosca M12

Conjunto Relógio comparador com suporte

Universal

📦 1.00 kg



CR 362 KIT

Kit ferramentas (5 pçs): Para alinhamento do comando de válvulas, Pino de sincronismo e
Ferramenta de pré- esticamento da corrente de distribuição. Veiculo: PORSCHE CAYANNE - GTS -
MOTOR: 4.8L 2007...2010 M-48/01-G. PORSCHE PANAMERA 3.6L 2010... 2013 M-46 e
4.8L 2009...2013 M-48-40



PORSCHE

📦 0.22 kg



CR 420

Jogo de ferramentas para :
 1- posicionar em sincronismo os comandos de válvulas: Renault Master 2.5 16 v (G9U)
 2- Pino para travar a polia da bomba injetora dos motores 2.5 e 2.8 BOXER/MASTER/JUMPER/ DUCATO.
 3- Dispositivo para aliviar a carga do tensionador da correia dentada dos motores 2.5 e 2.8 BOXER/ MASTER/JUMPER/ DUCATO .
 Composição das ferramentas: CR 236/CR225/CR238



1.32 kg



CR 421

Jogo de ferramentas para sincronismo: RENAULT MASTER 2.3 16V Turbo Diesel (M9T) /BOXER/ DUCATO/ JUMPER (Motores: FPT 2.3 F1A e F1C 3.0) Composição das ferramentas: CR 361/CR299/CR301.



1.50 kg



140 KIT

Kit de ferramentas para sincronismo veículos: Renault 1.0 / 1.6 8 e 16 v composição das ferramentas CR 140 A / B / C / D / E / F (6 PEÇAS)



2.33 kg



CR 342 Kit Fire

Jogo de ferramentas para sincronismo dos motores Fiat Fire: 8V e 16V (1.0/1.3/1.4) composição das Ferramentas: CR 109 / CR 110 / CR 111 / CR 133



1.88 kg



CR 343 KIT EVO I

Jogo de ferramentas para sincronismo dos motores Fiat EVO: 1.0/1.4 8V, e substituição do filtro de óleo composição das Ferramentas: CR 265 / CR 266 / CR 289

0.90 kg



CR 343 A KIT EVO II

Kit de ferramentas para sincronismo dos motores FIAT EVO 1.0/1.4 8v. Composição das ferramentas: CR 110/CR265/CR266

0.95 kg



CR 365

Kit de ferramentas para sincronismo do motor FIAT FIRE FLY 3cc 1.0 e 4 cc 1.3 UNO e MOBY

1.96 kg



CR 397 Kit

Kit de ferramentas para sincronismo dos motores MULT-JET (TURBO-DIESEL) 2.0 FIAT TORO/ JEEP RENEGADE/ COMPASS



1.49 kg



CR 473

Jogo c/ 2 ferramentas para sincronismo do motor E-TORQ-EVO 1.8 Flex 2016... Toro, Argo, Cronos e Renegade



1.75 kg



CR 326 S

Kit de ferramentas p/ sincronismo motor Ford Duratec 1.6-1 16V VTI (120cv) geração Sigma com comando de válvulas variável. veículos : New Fiesta / Focus / Ecosport 2014...



(composição das ferramentas CR 326 + 233 B)

1.76 kg



CR 326 KIT

Jogo de ferramentas para sincronismo motor Ford Duratec 1.6-1 16V VTI (120cv) geração Sigma com comando de válvulas variável . Veículos: New Fiesta / Focus / Ecosport 2014...



1.25 kg

CR 325 KIT THP



📦 2.39 kg

KIT de ferramentas p/ sincronismo dos veículos equipados c/ motores:
THP EP6 PSA 1.6/16V-TURBO N-14, SEM Valvetronic, MINI COOPER: S - 07...10
Cabrio - 09..12, Coupe - 11...12, Roadster - 11...12, Clubman - 08...10 CITROËN: C4 LOUNGE,
DS3, DS4, DS5. PEUGEOT: 308, 408, 508, 2008, 3008, RCZ



Universal CR 409

Ferramenta para girar o comando de válvulas a fim de fixar a ferramenta de sincronismo (fixação dos comandos). Veículos com chave de 8mm na parte traseira do comando.

📦 0.29 kg

CR 415

Ferramenta para
sincronismo motor
PSA PURE TECH 1.2
12V-3CIL. CITROËN C3
PEUGEOT 208 2016...



📦 1.34 kg



CR 235 A KIT

Kit com 12 peças para troca da correia dentada nos veículos: Peugeot e Citroën



📦 2.28 kg

Kit de ferramentas
para sincronismo
motor Ford
303 - 3 cil (85cv)
Duratec Ford KA



CR 327 S KIT

(composição das ferramentas CR 327 A+ 233 B)

📦 1.26 kg

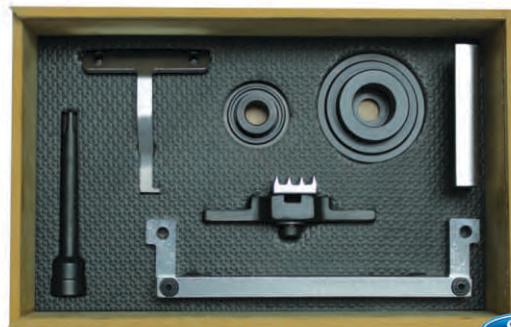

CR 462 KIT DRAGON

KIT com 7 peças para manutenção em motores FORD DRAGON 1.5L 3 CIL
(composição das ferramentas CR 451 / 453 / 454 / 455 / 456 / 458 / 459)

📦 2.53 kg

CR 312

Dispositivos (3pcs)
para imobilização
dos comandos
de válvulas :
GM CAPTIVA / OMEGA V6
3.0 e 3.6 com injeção direta



📦 0.45 kg

CR 312 S

Dispositivos (3pcs)
para imobilização
dos comandos
de válvulas :
GM CAPTIVA/
OMEGA V6
3.0 e 3.6



📦 0.84 kg

(Composição das ferramentas CR 312 + CR 233-A)



CR 316 KIT

Kit de ferramentas para sincronismo: GM CRUZE / SONIC ECOTEC



0.97 kg



CR 344 - KIT S10

Kit de ferramentas para sincronismo: 180 CV 2.8 turbo Diesel = (CR 298 + CR 298-A)
200 CV 2.8 Turbo diesel = (CR 298 + CR298-B) 206 CV 2.5 Ecotec = (CR 330)
composição das ferramentas: CR 298 / CR 298-A / CR 298-B / CR 330



1.43 kg



CR 319 KIT

Kit de ferramentas para sincronismo VW Amarok 2.0 Turbo



0.70 kg



CR 319 A KIT

Kit de ferramentas para sincronismo, remoção e instalação das polias dos eixos de comando e reinstalação do módulo da árvore intermediária (eixo cardã)



2.77 kg



CR 329 KIT

Kit de ferramentas para sincronismo dos motores VW 2.5 20V 5 cil. 150 CV e 170 CV Jetta e Variant (2006-2011)



0.76 kg



CR 336 KIT EA 211

Kit de ferramentas para sincronismo dos motores VW EA 211. Up / Up TSI/ Fox e Gol MSI G6-12 e 16V / Golf 1.4 TSI
composição das ferramentas: CR 336-A / B / C / D / E / F



3.20 kg



CR 336 Jogo

Jogo de ferramentas (5 Peças) para sincronismo dos motores EA 211: UP/UP TSI/FOX 12Ve GOL MSI 1.6 16V e GOLF 1.4 TSI (CR-336-A/B/C/D/E)



1.45 kg



CR 372 KIT

Kit de ferramentas para sincronismo do motor EA 888 1.6 / 2.0 16V TSI / T FSI. AUDI / JETTA / FUSCA / PASSAT / TIGUAN. Composição da ferramenta CR 331 / CR 332 / CR 371 / CR 389



3.08 kg



CR 177

Ferramenta para posicionar as polias de comando de válvulas em PMS.Audi: 2.4 / 2.7 / 2.8 - 12 e 30 V e Passat 30V

📦 2.29 kg



CR 177 A

Ferramenta para travar virabrequim:
Audi: 2.6 / 2.8 - 12V
2.4 / 2.7 / 2.8 / 3.0 e Passat 30V

📦 0.10 kg



CR 406

Ferramenta para ajuste do sincronismo dos camdos de válvulas:
AUDI A8 4.2L Motores: AKG,AKH de 1998 A 2003



📦 1.28 kg



CR 452 KIT

Kit de ferramentas para sincronismo: AUDI A1 TFSI 1.4 2010 a 2014
Motores: CAXA-CAVG-CNVA-CTHG



📦 0.93 kg



CR 390 Kit

Kit de ferramentas para sincronismo AUDI e PASSAT MOTOR FSI 2.0 L
2005....2009



📦 1.71 kg



CR 446 KIT

Kit de ferramentas para sincronismo: AUDI A4/A6 3.0 V6 de 2001 a 2008
(Motores: BBJ/ASN) e A4 3.0 2014.... (Motor: CZCA).



📦 2.54 kg



CR 424 KIT

Kit de ferramentas para sincronismo dos veículos AUDI: MOTORES: 3.2-24V – FSI V6 A4/A5
(motor CALA) 2007... A6-(motor CAJA) 2008... (CAJA)2012... Q5-(motor CALB)2007.....



📦 1.04 kg



CR 329 A KIT

Kit de ferramentas para sincronismo dos veículos AUDI : A8- Q7- RS5- RS6-
equipados com motores: 4.0 32V 8 TFSI/FSI 5.0 40V V10 TFSI 5.2 40V V10 FSI e
VW TOUAREG: 4.2 32V V8 FSI 4.2 40V V8 Cod dos motores:
CDRA-BVJ-BAR-BVH-BXA-BSM



📦 0.76 kg

**CR 347**

Jogo de ferramentas: para remover e instalar o sistema de dupla embreagem nos câmbios Dps6 **POWER SHIFT**

Obs: Somente para instalar o conjunto novo, esta ferramenta não faz o reset do conjunto retirado

📏 10.5 kg

**CR 347 A**

Jogo de ferramentas para RESETAR o sistema de dupla embreagem DPS6 POWER SHIFT

📏 5.13 kg

**CR 368**

Jogo de ferramentas p/ (des)montar o sistema de dupla embreagem do câmbio DSG 7 Velocidades. AUDI TSFI / JETTA / GOLF / TIGUAN / PASSAT 2.0 TSI

📏 11.6 kg

**CR 368 A**

Jogo de ferramentas para regulagem da altura do conjunto de embreagem DSG. Deve ser utilizado em conjunto com CR 368.

📏 6.08 kg

**CR 368 B**

Ferramenta para abrir a tampa do conjunto mecatrônica do câmbio DSG

📏 0.14 kg

**CR 368 C**

Haste de medição de profundidade do câmbio DSG 7 VELOCIDADES (15 x 20 x 800mm)

📏 1.87 kg

**CR 368 D**

Adaptador para ser utilizado com o EXTRATOR da ferramenta CR368, (que não acompanha este conjunto) para sacar a carcaça do câmbio juntamente com o rolamento

📏 1.28 kg

**CR 405**

Ferramenta de retenção Usado para montar embreagens no modelo / código 02E da VW e Audi 6 velocidades de mudança direta (DSG). VW/AUDI

📏 0.11 kg

CR 394

Conjunto de 8 dispositivos para encolher o pistão dos câmbios Automáticos c/ Auxílio de prensa.



📦 8.30 kg

Universal



CR 398

Ferramenta para instalação e remoção do sistema de dupla embreagem da transmissão de 6 velocidades DCT VOLVO C-30/70 S-40/60 V-40/50/60/70 XC-60



📦 1.49 kg



CR 419

Kit de ferramentas (8 peças) para :
1-comprimir a mola da embreagem.
2-Instalar o rolamento do corpo do pinhão.
3-Instalar o rolamento de agulhas.
4-Cabo auxiliar do instalador de rolamentos.
5-Extrator do rolamento de agulhas.
6-Instalador da junta da alavanca do câmbio.
7-Jogo (2 peças) para calibração da embreagem. Aplicação : Câmbios : 6HP26 /6HP28: LAND ROVER- BMW-AUDI e 6R60 FORD RANGER-EXPLORER

📦 5.68 kg



CR 387

Injetor para reposição do óleo nos câmbios DSG 7 velocidades: JETTA/PASSAT/GOLF/AUDI A3 A4 A5 Q3 TFSI (Medida da rosca do bujão) M 24X1,5

📦 0.88 kg

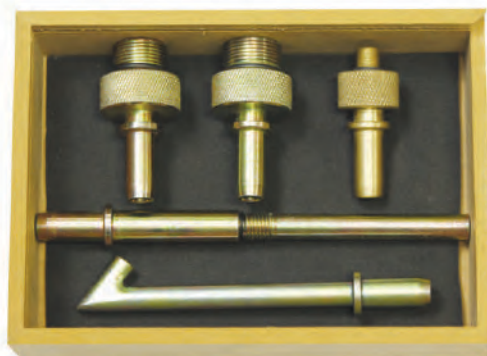

CR 448

Jogo de adaptadores para introdução de óleo nos câmbios :DSG - (448-04) M 24 X 1,5mm CVT- (448-02) M 22 X 1,5mm 09G- (448-05) M10 X 1mm 01J (448-03) sem rosca (curvo) MERCEDES (448-01) M12 x 1,5mm

📦 0.68 kg

11 Bancadas de Serviço - Suportes e Painéis

CR 11019

Bancada de serviço
1 gaveta



Lar. (mm)	Prof. (mm)	Alt. (mm)
1100	650	900

📦 52.0 kg



CR 11014

Bancada de serviço
2 gavetas

Lar. (mm)	Prof. (mm)	Alt. (mm)
1900	650	900

📦 85.0 kg



CR 11025



Bancada de serviço
700 x 400mm
(1 gaveta)

📦 23.0 kg

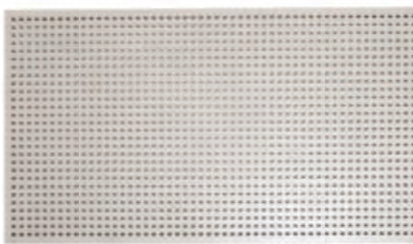

Bancadas de Serviços

- Alta resistência
- Pintura epóxi
- Bandeja reforçada
- Tampo de madeira 34mm
- Totalmente Desmontável
- Pés niveladores (Fixo)

CR 11026

Painel em chapa de aço
perfurada sem moldura e
pintura epóxi 960 X 550 mm

📦 6.00 kg

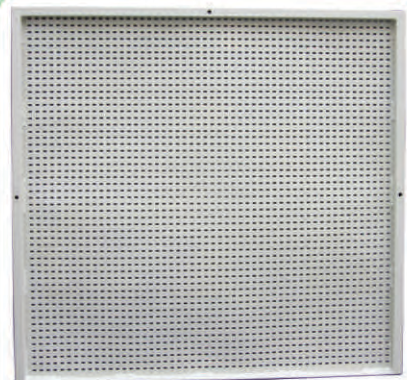

CR 11017

Painel em chapa de aço
perfurada com moldura e
pintura epóxi 1000 X 1000 mm

📦 16.0 kg

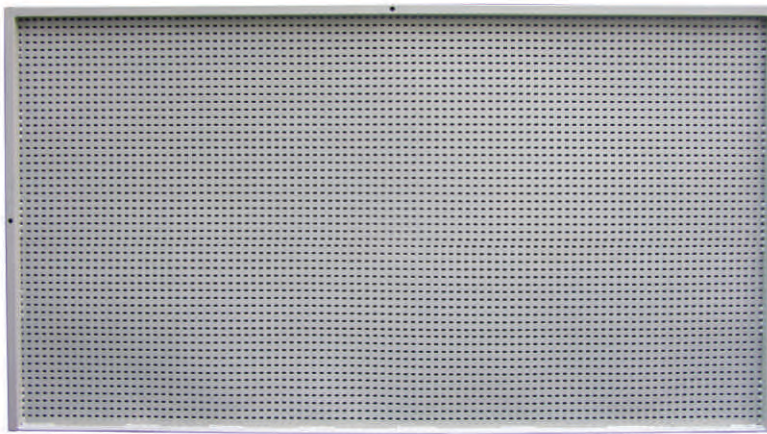

CR 11018

Painel em chapa de aço perfurada com moldura e pintura epóxi
1850 X 1000 mm

📦 25.5 kg



CR 11020

Manta emborrachada
1900 x 650 mm
(opcional)

📦 4.96 kg



CR 11021

Manta emborrachada
1100 x 650 mm
(opcional)

📦 3.87 kg

SUPORTES PARA CHAVE L



📦 1.27 kg

CR 27001

(G) 8 a 19mm
12 pçs.



📦 0.66 kg

CR 27002

(GBY) 6 a 15mm
10 pçs.



📦 0.79 kg

CR 27003

(GT) 6 a 19mm (28 L)
E6 a E24
8 pçs.



📦 0.31 kg

CR 27004

(GVZ) 10 a 14mm
5 pçs.



📦 0.52 kg

CR 27007

(29TXT) T20 a T60
9 pçs.



📦 0.53 kg

CR 27008

(29TXL) T20 a T60
Allen Longa
9 pçs.

SUPORTES PARA SOQUETES E CHAVES DE CABO RETO

CR 27006
Chave Soquete 6 pcs.
0.09 kg

CR 27009
Chave Soquete 9 pcs. (29TXS)
0.16 kg

CR 27010
(31TX) 7 pcs.
0.20 kg

CR 27049
(31E) 4 pcs.
0.06 kg

CR 27059
Longa 6 pcs.
0.21 kg

CR 27011
9 pcs. (CR 201)
0.20 kg

CR 27051
(Combinada 6 a 22mm) 15 pcs.
0.14 kg

CR 27047
(Combinada 6 a 32mm) 20 pcs.
0.25 kg

CR 27005
Chave "T" (15009) 7 pcs.
0.15 kg

CR 27058
12 pcs. Ch. Fixa
0.66 kg

CR 27064
Suporte de uso universal para chaves com cabo (10pcs) e soquetes (3pcs)
0.25 kg

CR 27069
Suporte para chaves allen / brocas (9pcs)
0.17 kg

CR 27070
Suporte para bits (11 pcs)
0.16 kg

SUPORTES 'CAIXA' ABERTA

CR 27048
30x190mm G 100 1/2 6 a 19mm (28S) E6 A E24
0.32 kg

CR 27050
30x330mm
0.62 kg

CR 27013
50x180mm G 100 3/4 27 a 33mm
0.48 kg

CR 27012
50x270mm G 100 3/4 17 a 27mm
0.72 kg

HORIZONTAL E VERTICAL

CR 27041
Suporte horizontal "Reto" 30mm
0.01 kg

CR 27042
Suporte horizontal "Reto" 55mm
0.01 kg

CR 27043
Suporte horizontal "Reto" 85mm
0.02 kg

CR 27044
Suporte Vertical "Reto" 30mm
0.01 kg

CR 27045
Suporte Vertical "Reto" 55mm
0.01 kg

CR 27046
Suporte Vertical "Reto" 85mm
0.02 kg

CR 27057
Suporte apoio reto 100x55mm
0.07 kg

CR 27065
Suporte tipo bandeja 110 X 70 mm
0.16 kg

CR 27055
Suporte horizontal em "C" 38mm
0.01 kg

CR 27056
Suporte horizontal em "C" 76mm
0.02 kg

Apoio Duplo

CÓD.	mm
27014	7
27015	10
27016	13
27017	16
27018	23
27019	26
27054	32
27020	39
27021	51
27022	60

Tratamento Superficial:
Bicromatizado

CR 27018 0.02 - 0.12 kg

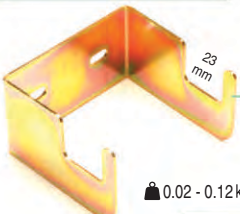

'U'

CÓD.	mm
27023	7
27024	10
27025	13
27026	16
27027	23
27028	26
27053	32
27029	39
27030	51
27031	60

CR 27027 0.01 - 0.06 kg

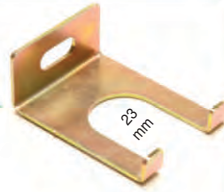

'O'

CÓD.	mm
27032	7
27033	10
27034	13
27035	16
27036	23
27037	26
27052	32
27038	39
27039	51
27040	60

CR 27036 0.03 - 0.09 kg

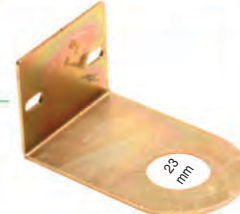

'O Duplo'

CÓD.	mm
27032 A	7
27033 A	10
27034 A	13
27035 A	16

CR 27035 A 0.03 - 0.05 kg

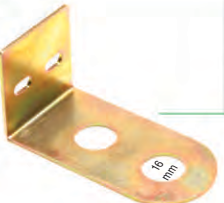

CR 27062
Suporte para
catraca e
acessórios (4pçs)

0.07 kg



0.12 kg

CR 27063
Suporte para chaves de fenda
e canhão (cotoco) 6 peças



'Alicates'

CÓD.	mm	kg
27060	Universal	0.05
27061	Bico / Anel / trava	0.04

CR 27060 0.05 kg **CR 27061** 0.04 kg



CR 27066
Suporte para
alicates tipo Ford

0.04 kg



CR 27067
Suporte para
alicates pressão

0.06 kg



CR 27068
Suporte para alicates bico /
corte / reto

0.15 kg



A Ferramenta na medida certa para sua Oficina.

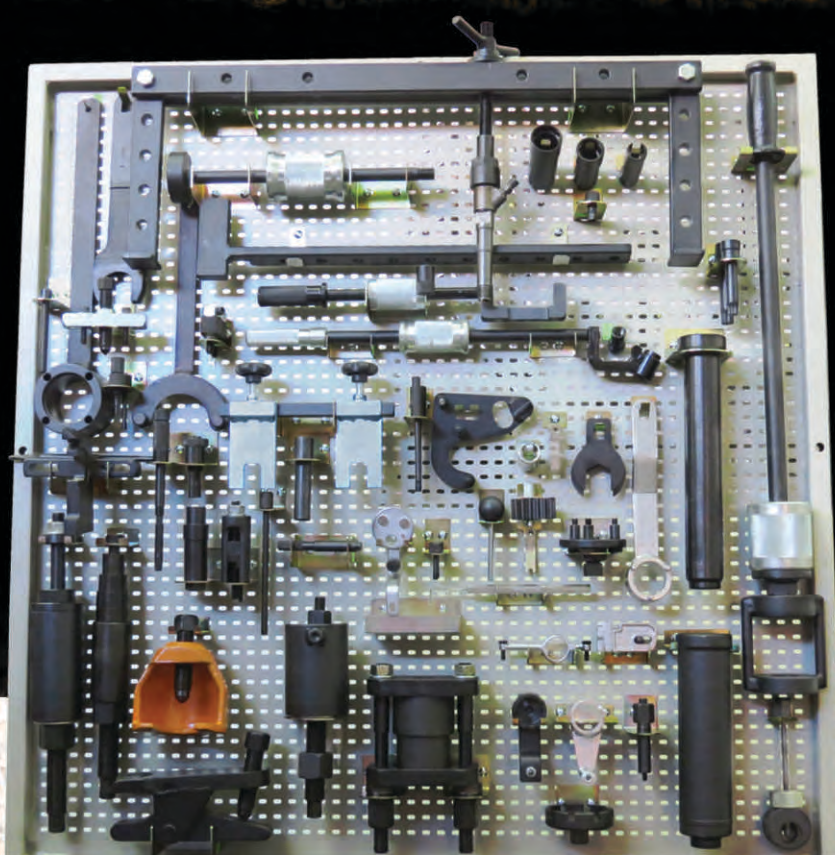

Siga-nos nas redes sociais e fique por dentro das Novidades e Lançamentos



[crautomotrixx](https://www.crautomotrixx.com.br)

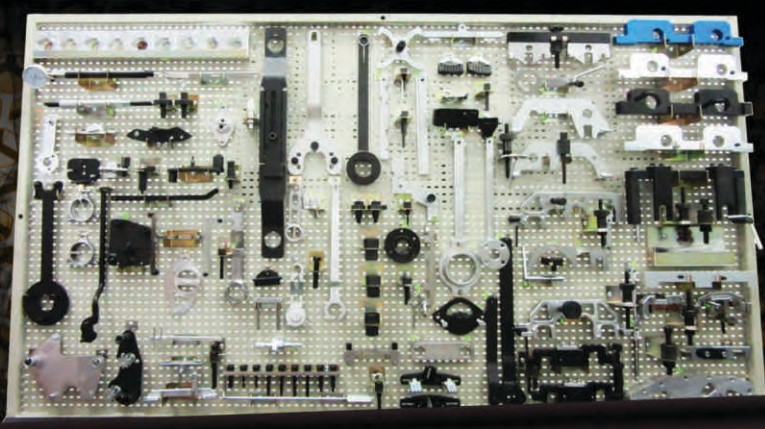
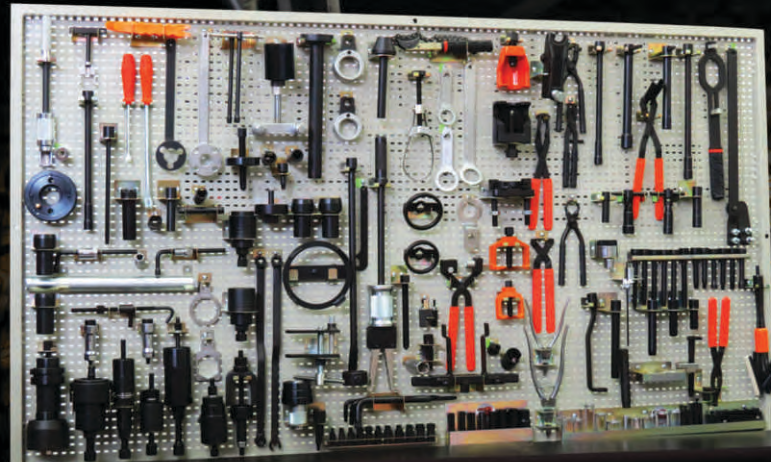

Fale conosco:

crautomotrixx@crautomotrixx.com.br



www.crautomotrixx.com.br

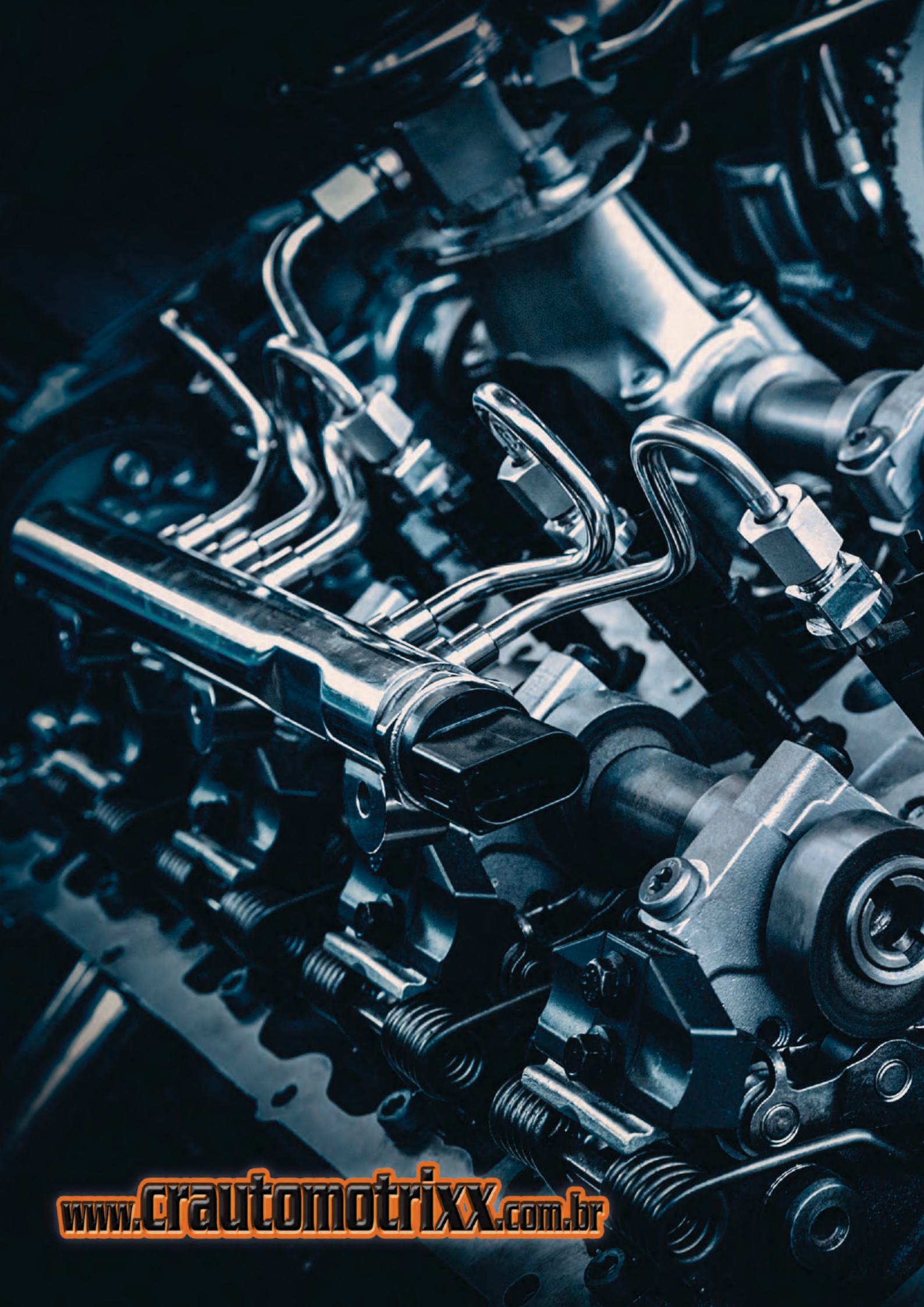

www.crautomotrixx.com.br